



basic education

Department:
Basic Education
REPUBLIC OF SOUTH AFRICA

**NATIONAL
SENIOR CERTIFICATE**

GRADE 12

ENGINEERING GRAPHICS AND DESIGN P2
NOVEMBER 2023

MARKS: 100

TIME: 3 hours

This question paper consists of 6 pages.

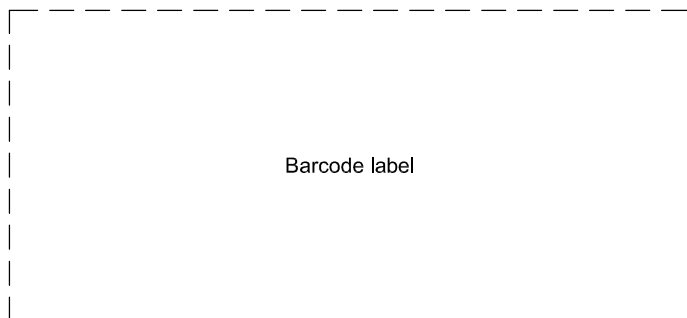

Barcode label

INSTRUCTIONS AND INFORMATION

1. This question paper consists of FOUR questions.
2. Answer ALL the questions.
3. ALL drawings are in third-angle orthographic projection, unless otherwise stated.
4. ALL drawings must be prepared using pencil and instruments, unless otherwise stated.
5. ALL answers must be drawn accurately and neatly.
6. ALL the questions must be answered on the QUESTION PAPER, as instructed.
7. ALL the pages, irrespective of whether the question was attempted or not, must be re-stapled in numerical sequence in the TOP LEFT-HAND CORNER ONLY.
8. Time management is essential in order to complete all the questions.
9. Print your examination number in the block provided on every page.
10. Any details or dimensions not given must be assumed in good proportion.

FOR OFFICIAL USE ONLY															
QUESTION	MARKS OBTAINED			$\frac{1}{2}$	SIGN	MODERATED			$\frac{1}{2}$	SIGN	RE-MARKING			$\frac{1}{2}$	SIGN
1															
2															
3															
4															
TOTAL															
	2	0	0			2	0	0			2	0	0		

FINAL CONVERTED MARK	CHECKED BY
100	

COMPLETE THE FOLLOWING:
CENTRE NUMBER
CENTRE NUMBER
EXAMINATION NUMBER
EXAMINATION NUMBER

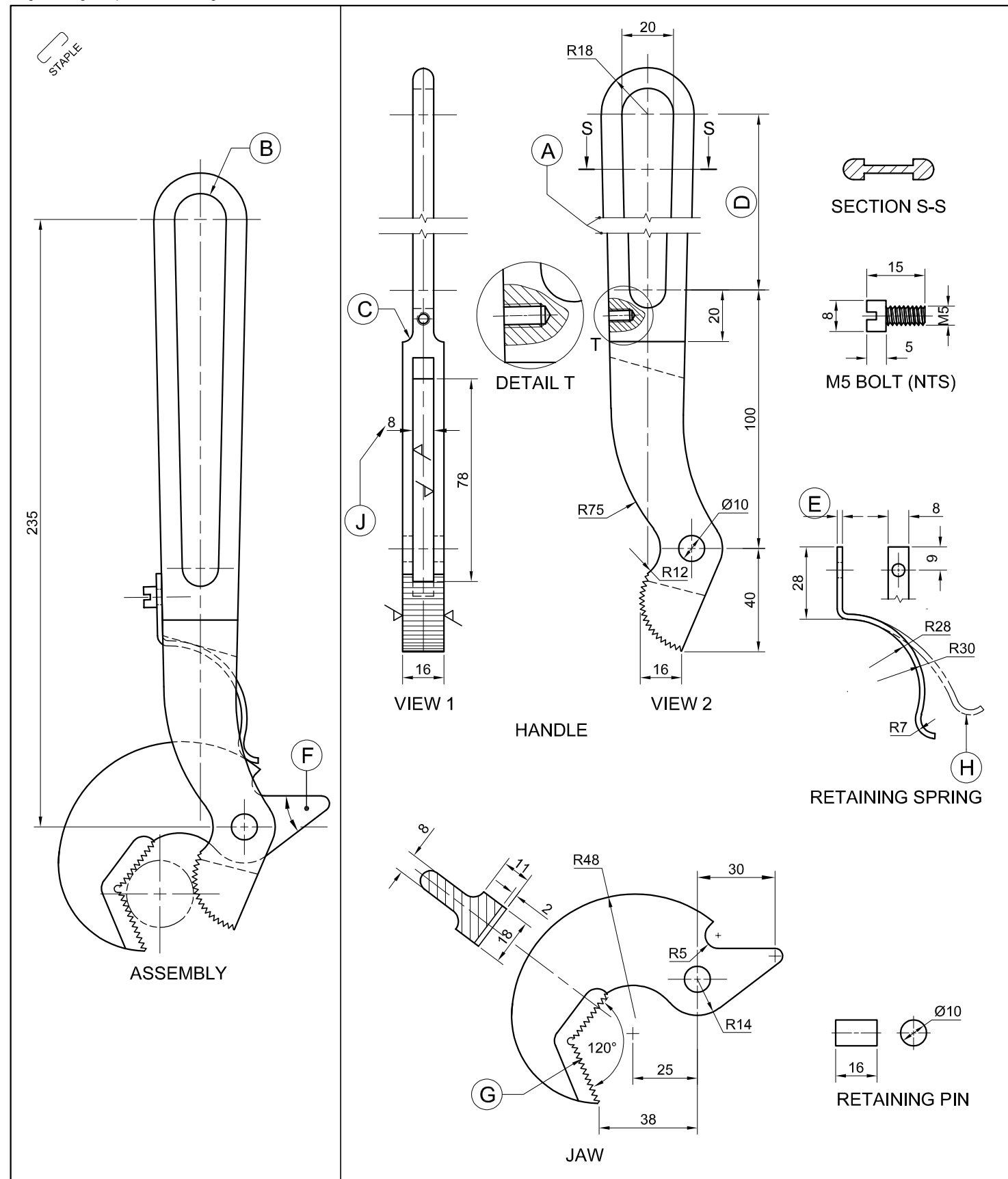

QUESTION 1: ANALYTICAL (MECHANICAL)

Given:
A view of the assembled pipe wrench, third-angle orthographic views of the parts of the pipe wrench, a title block and a table of questions. The drawings are not presented to the indicated scale.

Instructions:
Complete the table below by neatly answering the questions, which refer to the accompanying drawings, the title block and mechanical content. [30]

QUESTIONS		ANSWERS	
1	In which street is the manufacturer situated?	1	
2	What was done by Charles on 16/08/2022?	1	
3	What is the file name?	1	
4	What conventional representation is indicated by the break lines at A?	1	
5	What heating process is used for the tempering?	1	
6	What type of section is SECTION S-S?	1	
7	What type of section is shown in DETAIL T?	1	
8	Determine the complete dimensions at: B: C: D: E:	4	
9	Measure the angle at F.	1	
10	What is the depth of the teeth at G?	1	
11	What does the double-dash chain line at H indicate?	1	
12	How many surfaces on the pipe wrench must be machined?	1	
13	What does the abbreviation <i>NTS</i> stand for?	1	
14	If VIEW 1 is the front view of the handle, what would VIEW 2 be called?	1	
15	How many parts make up the pipe wrench assembly?	1	
16	With reference to the tolerance, determine the minimum and the maximum dimension at J.	2	
17	What is the direction of lay that is indicated by the machining symbol?	1	
18	What does the 0.2 on the machining symbol indicate?	1	
19	In the space below (ANSWER 19), redraw, in neat freehand and to the same size, the given end of a stud as a <i>SANS 10111</i> conventional representation.	4 1/2	
20	In the space below (ANSWER 20), draw, in neat freehand, the symbol for the projection system used.	3 1/2	
TOTAL		30	

FILE NAME: SCGG213	DRAWING No. WRC13	TOLERANCE: +0,23 -0,10	JJ HAND TOOLS CC www.toolsc.co.za CELL: 090 314 5839 84 SHARK STREET DURBAN 0110	HEAT TREATMENT: TEMPERING - 860° WITH INDUCTION HEATING
DRAWING PROGRAM: AUTOCAD 2022		SCALE 1 : 3	ALL UNSPECIFIED RADII ARE R4.	
DRAWN BY: NOMVUNDO	DATE: 02/07/2022	TITLE: PIPE WRENCH ASSEMBLY		
CHECKED BY: CHRIS	DATE: 09/08/2022			
APPROVED BY: CHARLES	DATE: 16/08/2022			

ANSWER 19	ANSWER 20
DETAILED REPRESENTATION	CONVENTIONAL REPRESENTATION
SYMBOL	
EXAMINATION NUMBER	
EXAMINATION NUMBER	



QUESTION 2: LOCI

NOTE: Answer QUESTIONS 2.1 and 2.2.

2.1 MECHANISM

Given:

- A schematic drawing of a mechanism consisting of crank OA, sliding rod AB, horizontal groove FG and rod DE in the vertical position
- The position of centre point O on the drawing sheet

Specifications and motion:

- The positions of centre point O and point D are fixed.
- Sliding rod AB is pin-jointed at A.
- Guide B slides in groove FG.
- Rod DE is pin-jointed at D.
- Rod DE slides through guide B.
- As crank OA rotates, guide B slides back and forth in groove FG, causing rod DE to oscillate.

Instructions:

- Draw, to scale 1 : 1, the given schematic drawing of the mechanism.
- Trace the loci generated by point C and by point E for ONE complete rotation of crank OA.
- Show ALL construction. **[19]**

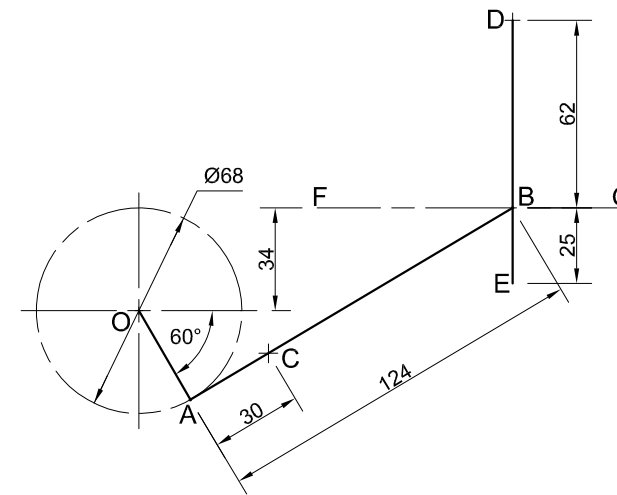

O+

ASSESSMENT CRITERIA 2.1			
1	GIVEN	6	
2	CONSTRUCTION	3	
3	POINTS + CURVE	10	
PENALTIES (-)			
SUBTOTAL 2.1		19	

2.2: CAM

Given:

The wedge-shaped follower and the camshaft, as well as the first 180° of the cam profile and the displacement graph in the correct position

Motion:

- The cam imparts the following motion to the given follower over the next 180°:
- There is a dwell period for 45°.
- It moves inwards to the minimum displacement with uniform acceleration and retardation over the next 90°.
- There is a dwell period over the remainder of the rotation.

Instructions:

- Using a rotational scale of 10 mm = 30° and a displacement scale of 1 : 1, complete the displacement graph by adding the required motion.
- Label the displacement graph and include the rotational scale.
- Project and complete the cam profile.
- Indicate the rotation direction with an arrow.
- Show ALL construction and projection. **[19]**

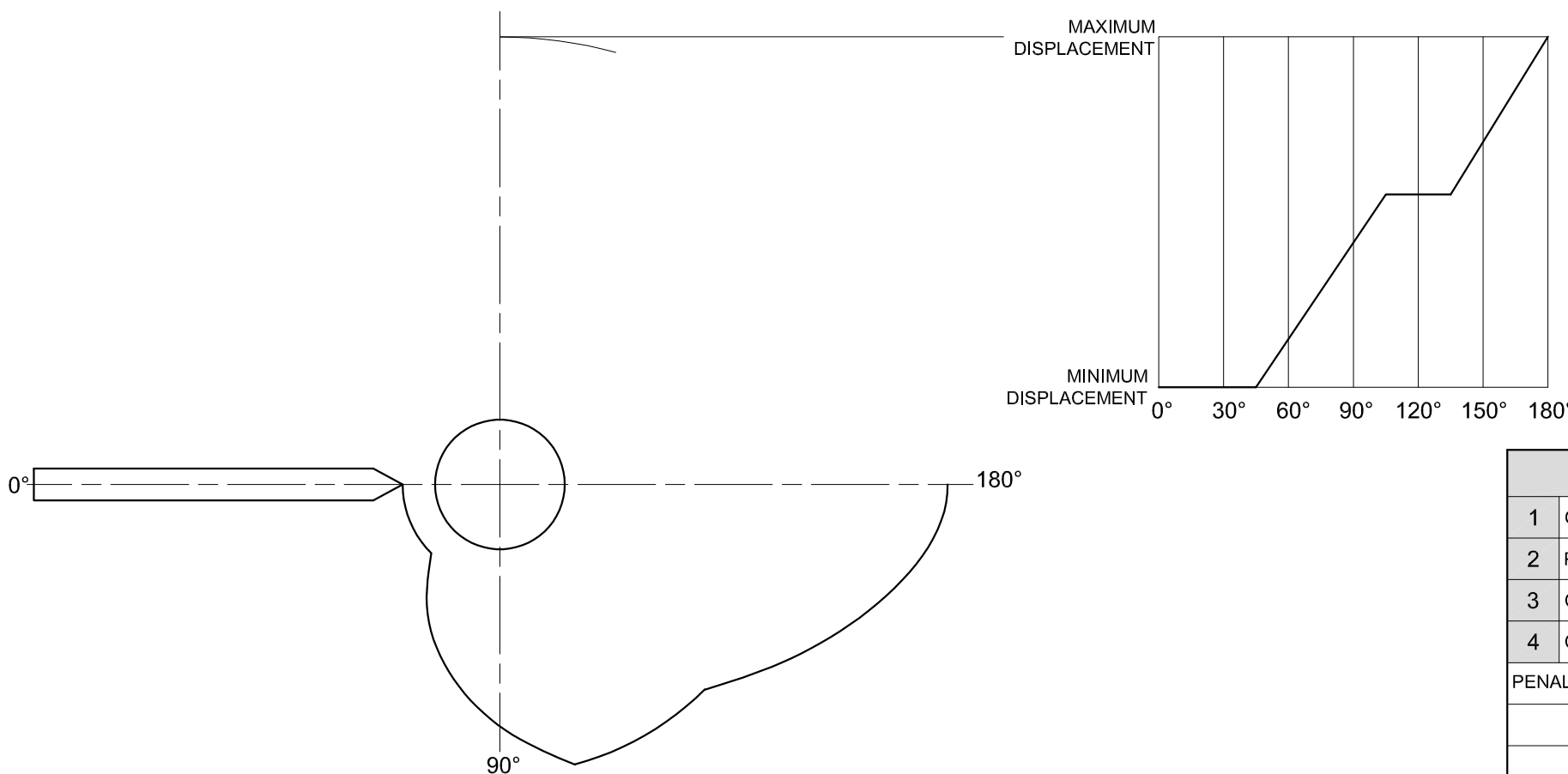

ASSESSMENT CRITERIA 2.2			
1	GRAPH CONSTRUCTION	5	
2	PLOTTING GRAPH	5 1/2	
3	CAM CONSTRUCTION	3	
4	CAM + CURVE QUALITY	5 1/2	
PENALTIES (-)			
SUBTOTAL 2.2		19	
SUBTOTAL 2.1		19	
TOTAL		38	

EXAMINATION NUMBER	
EXAMINATION NUMBER	3



QUESTION 3: ISOMETRIC DRAWING

Given:

- The front view, top view and right view of a SLIDING GUIDE casting
- The position of point P on the drawing sheet

Instructions:

Using scale 1 : 1, convert the orthographic views of the SLIDING GUIDE casting into a sectional isometric drawing on cutting plane A-A.

- Make P the lowest point of the drawing.
- Show ALL construction.
- NO hidden detail is required.

[40]

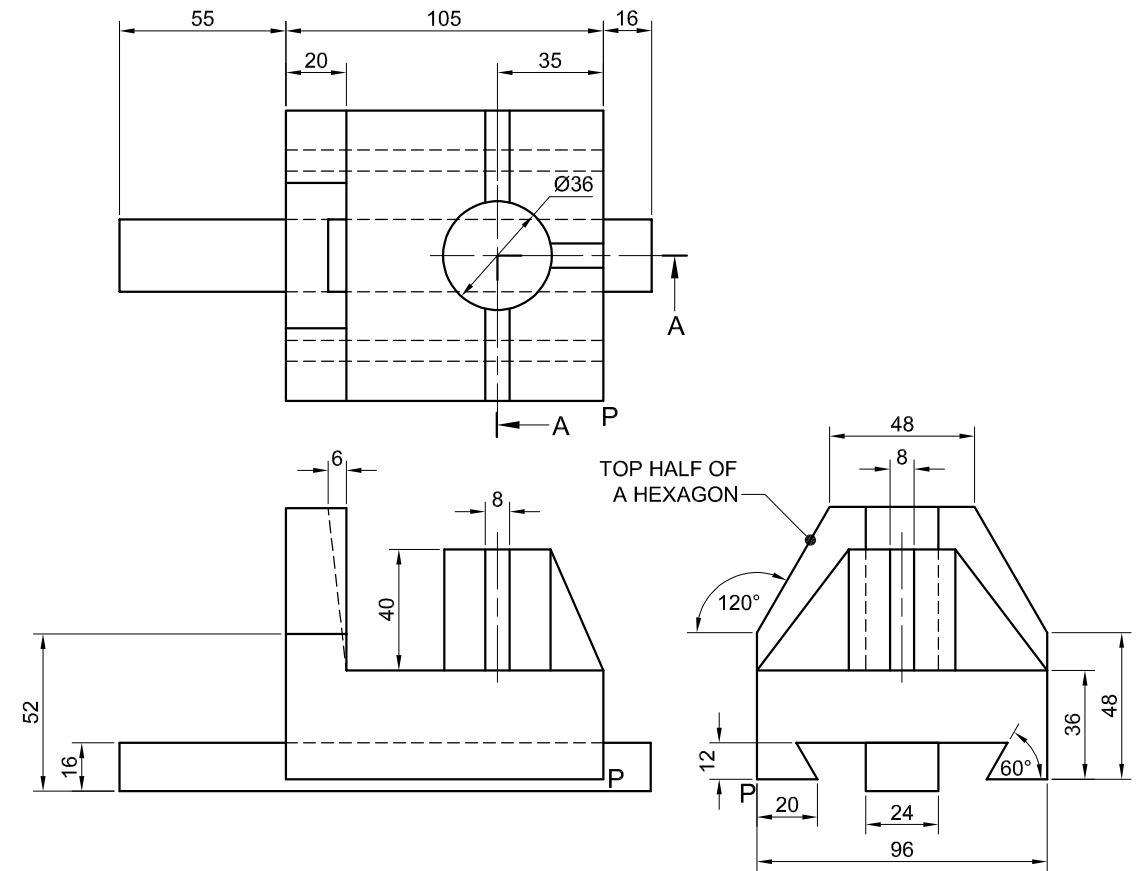

↓
P

ASSESSMENT CRITERIA			
1	PLACING + AUX. VIEWS	2	
2	FRONT + MIDDLE SURFACES	20	
3	SECTIONED SURFACE + HATCHING	12	
4	CIRCLE + CL	6	
PENALTIES (-)			
TOTAL		40	
EXAMINATION NUMBER			
EXAMINATION NUMBER			
EXAMINATION NUMBER			4

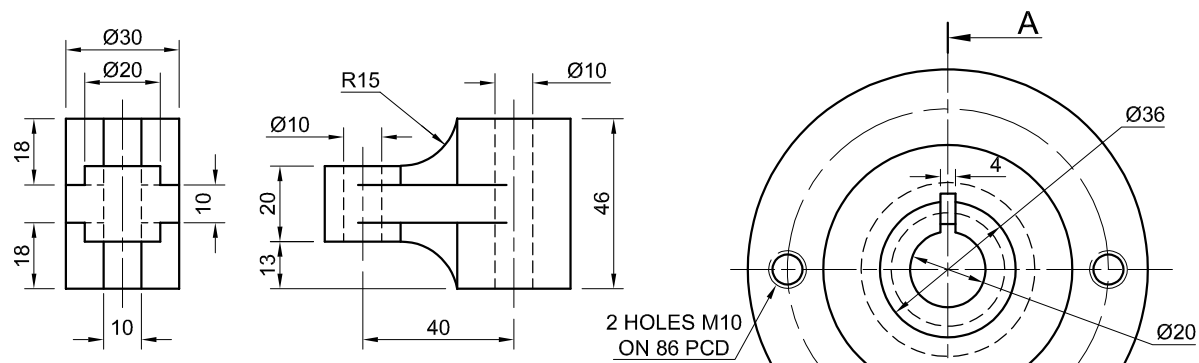

BRACKET [1]

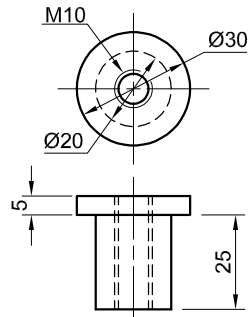

BUSH [2]

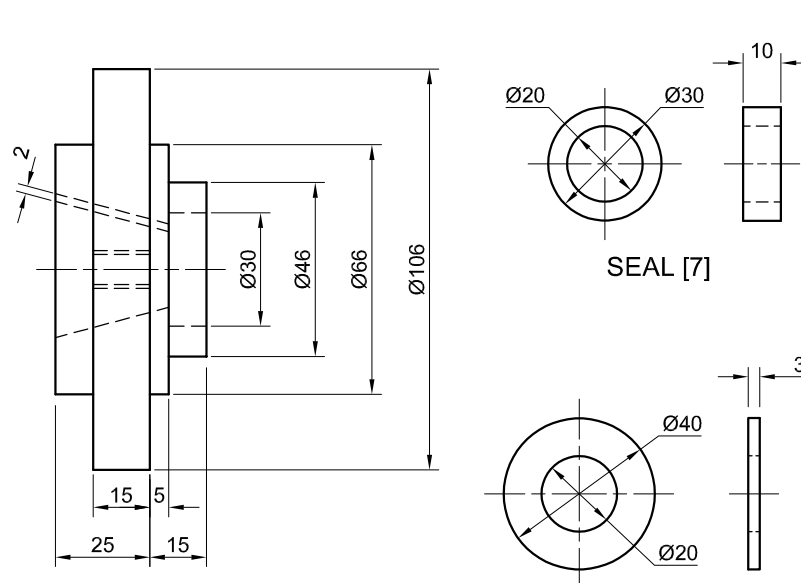

FLANGE [6]

SEAL [7]

WASHER [8]

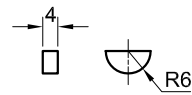

WOODRUFF KEY [5]

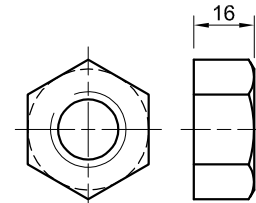

M20 NUT [9]

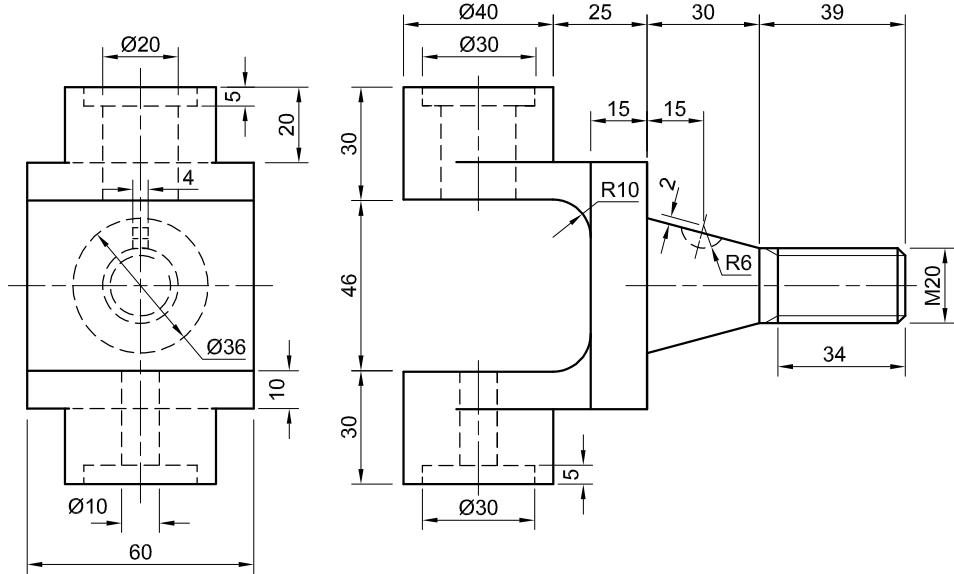

COUPLING [3]

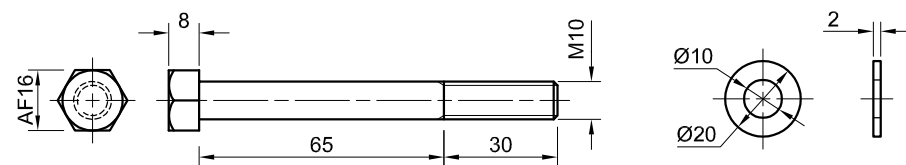

M10 BOLT + WASHER [4]

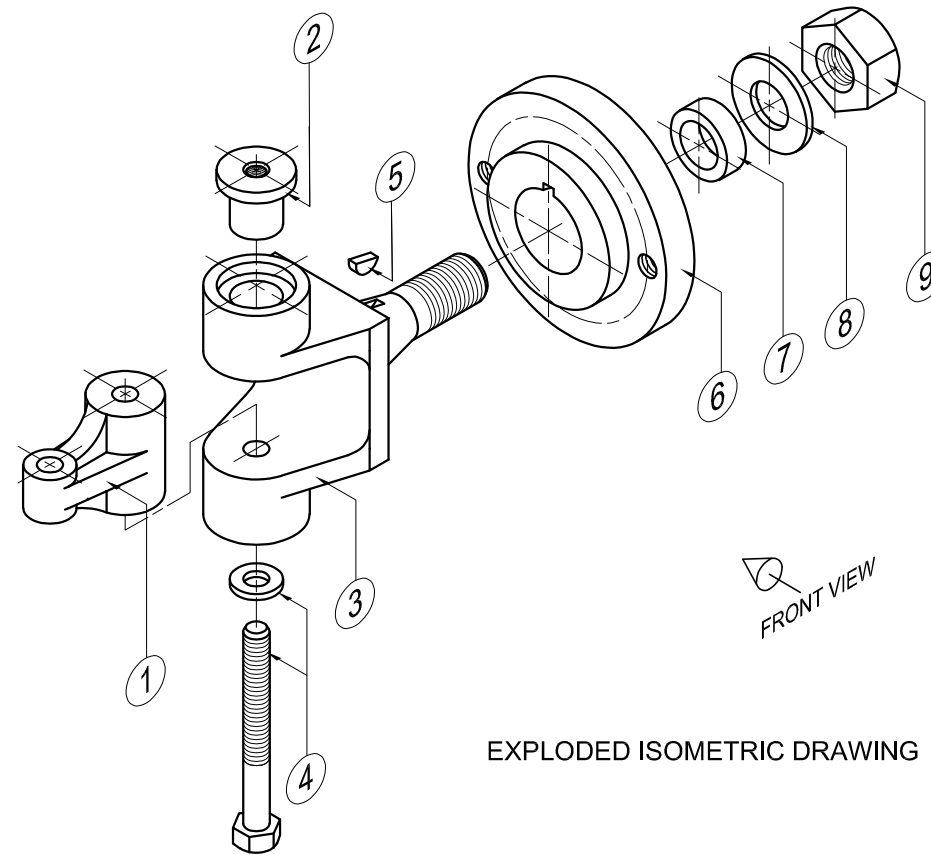

EXPLODED ISOMETRIC DRAWING

QUESTION 4: MECHANICAL ASSEMBLY

Given:

- The exploded isometric drawing of the parts of a coupling assembly, showing the position of each part relative to all the others
- Orthographic views of each part of the coupling assembly

Instructions:

- Answer this question on page 6.
- Draw, to scale 1 : 1 and in third-angle orthographic projection, the following views of the assembled parts of the coupling assembly:
 - 4.1 **A sectional front view** on cutting plane A-A as seen from the direction of the arrow on the exploded isometric drawing. The cutting plane is shown on the left view of the flange (part 6).
 - 4.2 **The left view**

NOTE:

- Planning is essential.
- The drawing must comply with the SANS 10111 guidelines.
- The convention of symmetry may NOT be applied.
- Show THREE faces of the M20 NUT (part 9) on the sectional front view.
- Show TWO faces of the M10 BOLT (part 4) on the sectional front view.
- NO hidden detail is required.

[92]

PARTS LIST			
	PART	QUANTITY	MATERIAL
1	BRACKET	1	MILD STEEL
2	BUSH	1	BRONZE
3	COUPLING	1	MILD STEEL
4	M10 HEXAGONAL BOLT + WASHER	1	STEEL
5	WOODRUFF KEY	1	MILD STEEL
6	FLANGE	1	MILD STEEL
7	SEAL	1	RUBBER
8	WASHER	1	STEEL
9	M20 HEXAGONAL NUT	1	STEEL

BOUNTY
ENGINEERING CC

25 JUSTICE STREET
GLENVIEW
www.bounty.co.za
031 345 7869

COUPLING ASSEMBLY

ALL DIMENSIONS ARE IN MILLIMETRES.

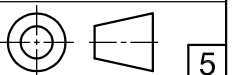

5



FOR OFFICIAL USE ONLY	
INCORRECT ORTHOGRAPHIC PROJECTION	
INCORRECT OVERALL SCALE	
INCORRECT HATCHING	
PARTS NOT ASSEMBLED	
TOTAL PENALTIES (-)	

ASSESSMENT CRITERIA					
LEFT VIEW					
		POSSIBLE	OBTAINED	SIGN	MODERATED
1	BRACKET	5			
2	COUPLING	6			
3	FLANGE	5 $\frac{1}{2}$			
4	M10 HEX. BOLT	3 $\frac{1}{2}$			
SUBTOTAL		20			
SECTIONAL FRONT VIEW					
1	BRACKET	10 $\frac{1}{2}$			
2	BUSH	5			
3	COUPLING	18 $\frac{1}{2}$			
4	M10 HEX. BOLT	8			
5	WOODRUFF KEY	2 $\frac{1}{2}$			
6	FLANGE	8			
7	SEAL	2			
8	WASHER + M20 NUT	5 $\frac{1}{2}$			
SUBTOTAL		60			
GENERAL					
1	CENTRE LINES	3			
2	ASSEMBLY	9			
SUBTOTAL		12			
TOTAL		92			
PENALTIES (-)					
GRAND TOTAL					
EXAMINATION NUMBER					
EXAMINATION NUMBER					
EXAMINATION NUMBER					