



# basic education

Department:  
Basic Education  
**REPUBLIC OF SOUTH AFRICA**

**SENIOR CERTIFICATE/  
NATIONAL SENIOR CERTIFICATE**

**GRADE 12**

**MCTW.1**  
**MECHANICAL TECHNOLOGY: WELDING AND METALWORK**  
**NOVEMBER 2020**

**MARKS: 200**

**TIME: 3 hours**

This question paper consists of 16 pages and a 1-page formula sheet.

# **AFTERNOON SESSION**



**INSTRUCTIONS AND INFORMATION**

1. Write your centre number and examination number in the spaces provided on the ANSWER BOOK.
2. Read ALL the questions carefully.
3. Answer ALL the questions.
4. Number the answers correctly according to the numbering system used in this question paper.
5. Start EACH question on a NEW page.
6. Show ALL calculations and units. Round off final answers to TWO decimal places.
7. Candidates may use non-programmable scientific calculators and drawing instruments.
8. The value of gravitational acceleration should be taken as  $10 \text{ m/s}^2$ .
9. All dimensions are in millimetres, unless stated otherwise in the question.
10. Write neatly and legibly.
11. A formula sheet is attached at the end of the question paper.
12. Use the criteria below to assist you in managing your time.

| QUESTION | CONTENT                                   | MARKS      | TIME<br>in minutes |
|----------|---|------------|--------------------|
|          | <b>GENERIC</b>                            |            |                    |
| 1        | Multiple-choice Questions                 | 6          | 6                  |
| 2        | Safety                                    | 10         | 10                 |
| 3        | Materials                                 | 14         | 14                 |
|          | <b>SPECIFIC</b>                           |            |                    |
| 4        | Multiple-choice Questions                 | 14         | 10                 |
| 5        | Terminology (Templates)                   | 23         | 20                 |
| 6        | Tools and Equipment                       | 18         | 15                 |
| 7        | Forces                                    | 45         | 30                 |
| 8        | Joining Methods (Inspection of Welds)     | 23         | 20                 |
| 9        | Joining Methods (Stresses and Distortion) | 18         | 20                 |
| 10       | Maintenance                               | 9          | 10                 |
| 11       | Terminology (Development)                 | 20         | 25                 |
|          | <b>TOTAL</b>                              | <b>200</b> | <b>180</b>         |



**QUESTION 1: MULTIPLE-CHOICE QUESTIONS (GENERIC)**

Various options are provided as possible answers to the following questions. Choose the answer and write only the letter (A–D) next to the question numbers (1.1 to 1.6) in the ANSWER BOOK, e.g. 1.7 A.

- 1.1 What is the purpose of the Occupational Health and Safety Act, 1993 (Act 85 of 1993) with regard to HIV/Aids awareness?
- A The Act on safety states that all employers must make sure that the workplace is safe and that employees are not at risk of becoming infected with HIV at work.
  - B The Act contains common guidelines on how employers, employees and trade unions should respond to HIV in the workplace.
  - C Employers may not demote or promote employees based on their HIV status.
  - D Employers cannot simply dismiss a person who has been infected with HIV. (1)
- 1.2 Which ONE of the following pieces of personal protective equipment is applicable when using a drill press?
- A Hard hat
  - B Apron
  - C Surgical gloves
  - D Safety goggles (1)
- 1.3 Which statement describes the placing of the machines in a product layout?
- A The machines are arranged in the sequence in which operations are carried out.
  - B The machines are arranged according to the worker's skills.
  - C The machines are grouped according to their types of operation.
  - D The machines are arranged according to the products. (1)
- 1.4 Which heat-treatment process is used to give steel a high resistance against wear?
- A Annealing
  - B Tempering
  - C Hardening
  - D Normalising (1)
- 1.5 The purpose of tempering steel is to...
- A harden it.
  - B increase the toughness.
  - C soften it.
  - D cool it down. (1)



- 1.6 Which test uses an indenter to determine the hardness of steel?
- A Sound test
  - B Rockwell test
  - C Bending test
  - D Machining test
- (1)  
**[6]**

### QUESTION 2: SAFETY (GENERIC)

- 2.1 What safety rule must be adhered to after work procedures on a machine have been completed? (1)
- 2.2 State TWO safety precautions that must be adhered to after the horizontal band saw has been switched on. (2)
- 2.3 Give TWO reasons why surgical gloves must be worn when treating a co-worker with open wounds. (2)
- 2.4 State TWO pieces of personal protective equipment (PPE) which must be worn during arc welding. (2)
- 2.5 Describe the responsibility of an employer regarding the safety and health of the employees in the workplace. (2)
- 2.6 Who is responsible for administering first aid to an injured person at the workplace? (1)  
**[10]**

### QUESTION 3: MATERIALS (GENERIC)

- 3.1 Explain how you will conduct the following tests to identify various metals:
- 3.1.1 Sound test (2)
  - 3.1.2 File test (2)
- 3.2 What is the purpose of the heat treatment of steel? (2)
- 3.3 What is the purpose of the case hardening of steel? (2)
- 3.4 Describe the *tempering process* of steel. (3)
- 3.5 Name the THREE factors which need to be taken into consideration when heat treatment of steel is done. (3)  
**[14]**



**QUESTION 4: MULTIPLE-CHOICE QUESTIONS (SPECIFIC)**

Various options are provided as possible answers to the following questions. Choose the answer and write only the letter (A–D) next to the question numbers (4.1 to 4.14) in the ANSWER BOOK, e.g. 4.15 A.

4.1 Which ONE of the following machine tools is used in the template loft?

- A Welding machine
- B Drilling machine
- C Grinding machine
- D Guillotine

(1)

4.2 Which weld position is indicated by the weld symbol in FIGURE 4.2?

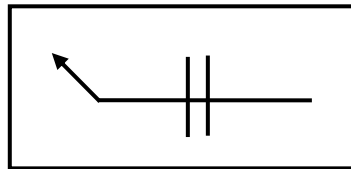
**FIGURE 4.2**

- A Weld on both sides
- B Weld on arrow side
- C Weld on other side
- D Weld on top side

(1)

4.3 Which ONE of the following is used by a hydraulic press in its operation?

- A Air
- B Water
- C Oil
- D Grease

(1)

4.4 The purpose of inert gas in MIGS/MAGS welding is to ...

- A hold a work piece together during welding.
- B protect the flux-coated electrode.
- C create a molten pool for electrode feed.
- D shield the molten pool from atmospheric gases.

(1)

4.5 Identify the welding process shown in FIGURE 4.5 below:

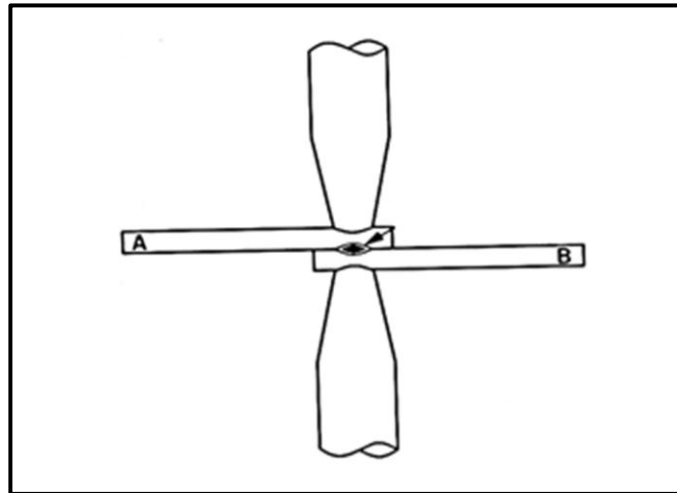
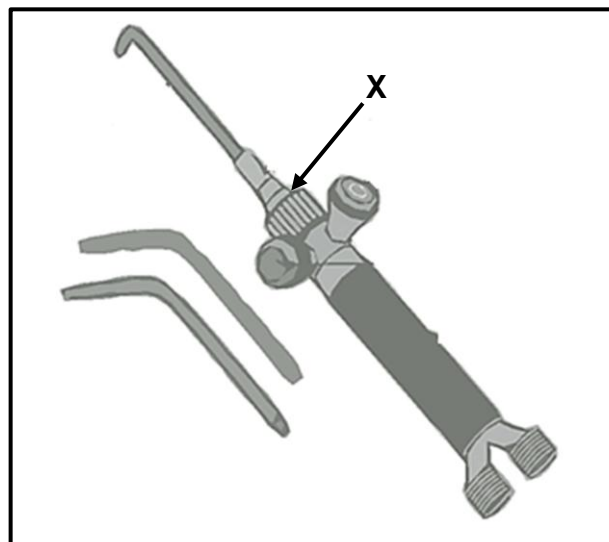

**FIGURE 4.5**

- A Arc welding
- B Spot welding
- C Oxy-acetylene welding
- D Gas welding

(1)

4.6 FIGURE 4.6 below shows a blowtorch. Component X indicated on the diagram is the ...

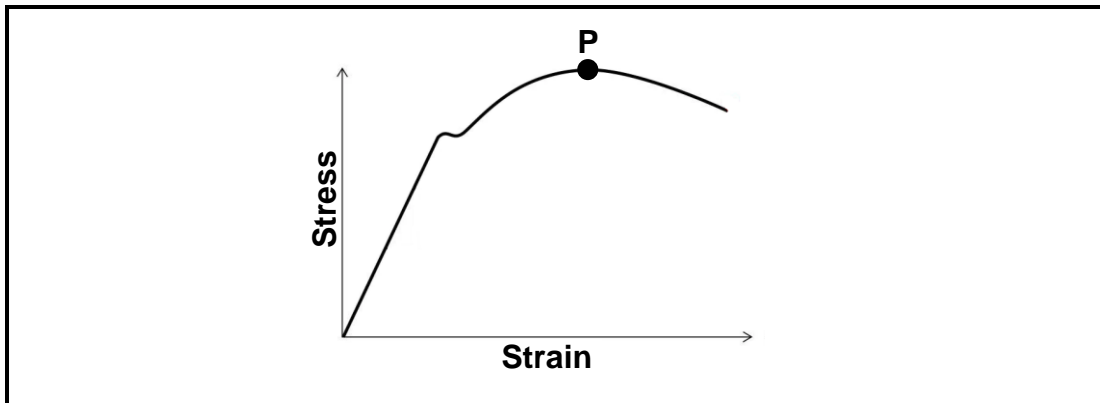

**FIGURE 4.6**

- A nozzle.
- B oxygen valve.
- C torch body.
- D mixing chamber.

(1)

4.7 FIGURE 4.7 below shows the stress-strain graph obtained during a tensile test on mild steel. What is indicated by P in the graph?



**FIGURE 4.7**

- A Maximum stress
- B Break stress
- C Elasticity limit
- D Yield point

(1)

4.8 Original length is defined as the ...

- A ratio between stress and strain.
- B length by which an object is shortened or lengthened.
- C length of an object before an external load is applied.
- D length of an object after an external load is applied.

(1)

4.9 Identify the type of machine is shown in FIGURE 4.9 below:

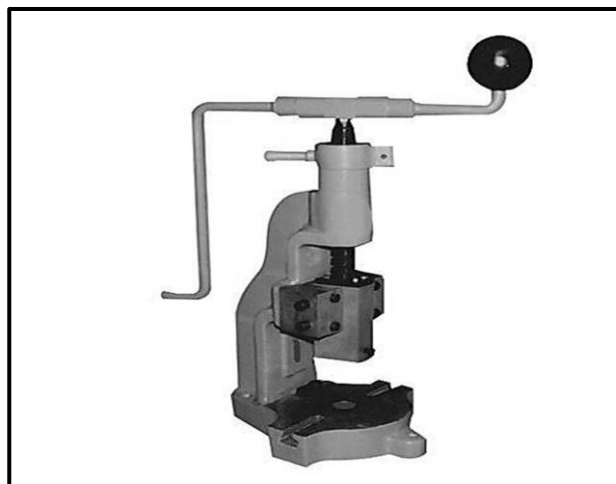
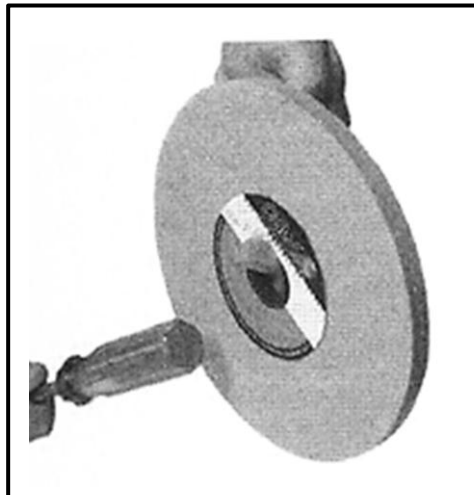

**FIGURE 4.9**

- A Hydraulic press
- B Power-driven press
- C Drill press
- D Fly press

(1)

- 4.10 Which ONE of the following determines the effect on shrinkage when performing arc welding?
- A Amount of gas
  - B Surface area
  - C Type of electrode
  - D Type of spark
- (1)
- 4.11 Ultrasonic inspection techniques use ... to detect flaws in welded joints.
- A liquid dye
  - B sound waves
  - C X-rays
  - D light rays
- (1)
- 4.12 The maximum plate thickness that can be cut with a manual guillotine is ...
- A 2 mm.
  - B 3 mm.
  - C 1,2 mm.
  - D 1,3 mm.
- (1)
- 4.13 FIGURE 4.13 below indicates a procedure performed on a grinding wheel. Which aspect is addressed with this procedure?



**FIGURE 4.13**

- A Checking for cracks in the grinding wheel
  - B Investigating the sidewalls of the grinding wheel
  - C Determining the coarseness of the grinding wheel
  - D Checking the roundness of the grinding wheel
- (1)



4.14 Calculate the value of  $\theta$ , as indicated in FIGURE 4.14 below:

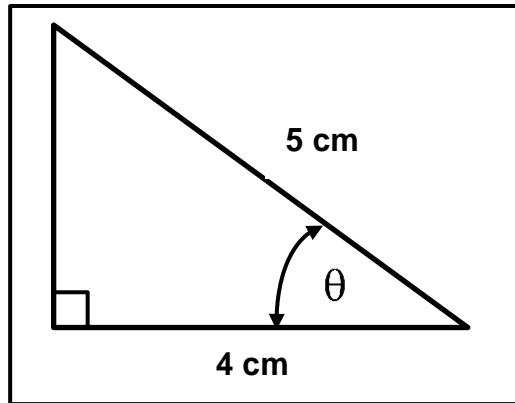

FIGURE 4.14

- A 53,12°
- B 38,66°
- C 53,13°
- D 36,87°

(1)  
[14]

**QUESTION 5: TERMINOLOGY (TEMPLATES) (SPECIFIC)**

5.1 Name TWO advantages of using templates. (2)

5.2 State ONE use of a template made from EACH of the following materials:

5.2.1 Thin metal (1)

5.2.2 Hardboard (1)

5.3 FIGURE 5.3 below shows a roof truss. Label parts A–E.

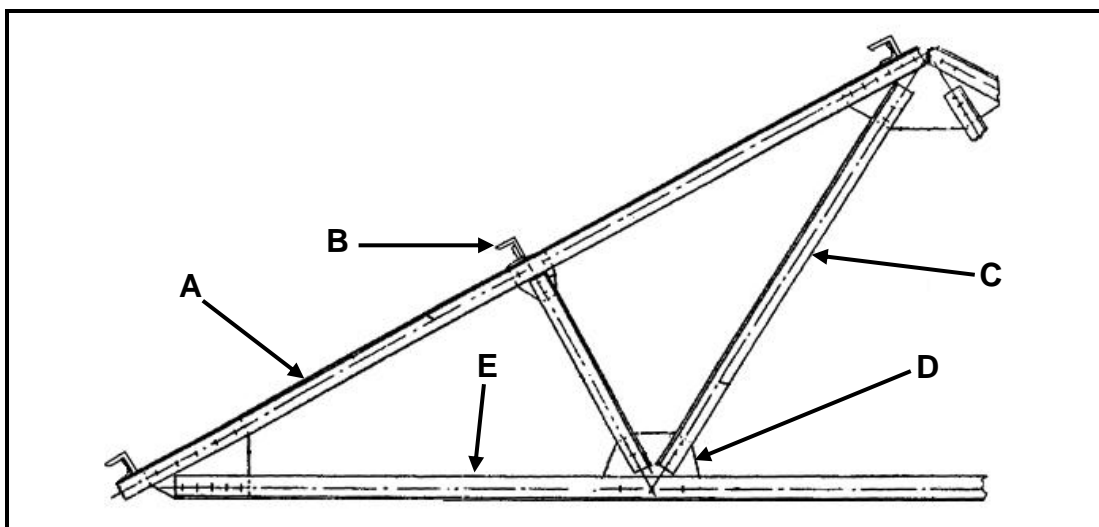

FIGURE 5.3

(5)

5.4 A mild steel ring with an outside diameter of 280 mm must be fabricated from 12 x 12 mm square bar. Calculate the dimensions of the required material to fabricate the steel ring. (5)

5.5 What does the abbreviation SANS stand for? (2)

5.6 Identify the resistance weld symbols in FIGURES 5.6.1 and 5.6.2 below.

5.6.1

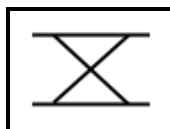

FIGURE 5.6.1 (1)

5.6.2

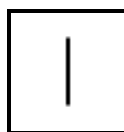

FIGURE 5.6.2 (1)

5.7 State the meaning of the dimensions of the weld indicated in FIGURE 5.7 below.

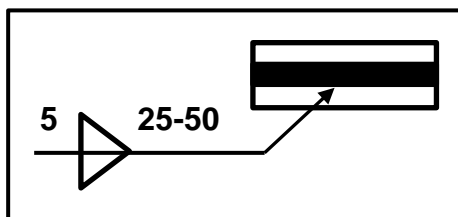

FIGURE 5.7 (3)

5.8 Identify the positions of the welds, as indicated by the welding symbols in FIGURES 5.8.1 and 5.8.2 below.

5.8.1

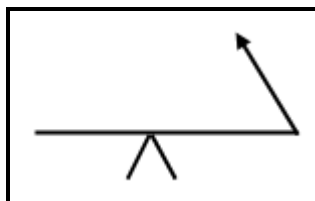

FIGURE 5.8.1 (1)

5.8.2

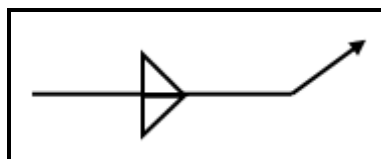
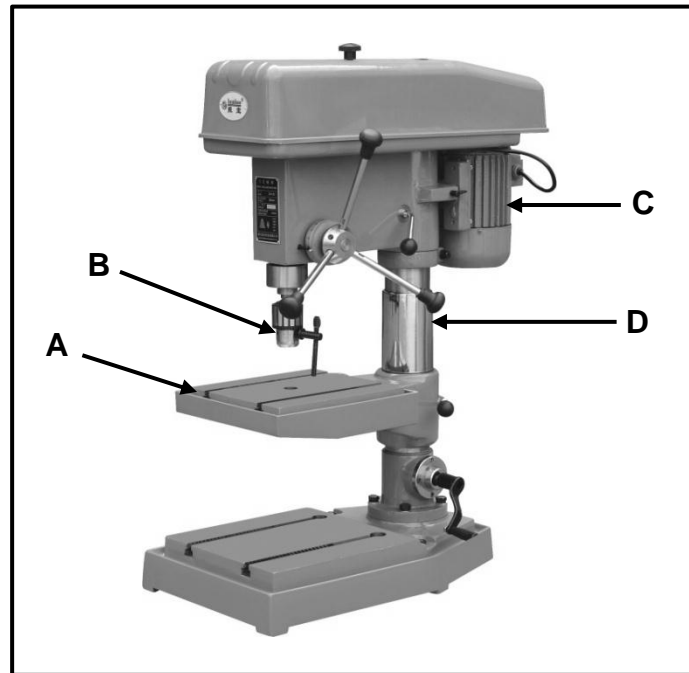

FIGURE 5.8.2 (1)  
[23]

**QUESTION 6: TOOLS AND EQUIPMENT (SPECIFIC)**

6.1 FIGURE 6.1 below shows a pedestal drill. Label parts **A–D**.



**FIGURE 6.1**

(4)

6.2 Explain the operating principles of the following machines that are used in the welding workshop:

6.2.1 Horizontal band saw (4)

6.2.2 Punch and shear (cropper) machine (3)

6.3 Name **THREE** primary functions of flashback arresters fitted to the gas cylinders of oxy-acetylene equipment. (3)

6.4 Name **FOUR** uses of taps and dies in the mechanical workshop. (4)

**[18]**

**QUESTION 7: FORCES (SPECIFIC)**

7.1 FIGURE 7.1 below shows a steel framework. Answer the questions that follows.

SCALE: Space diagram: 1 : 100  
Force/Vector diagram: 1 mm = 10 kN  
Tolerance: ± 3 mm

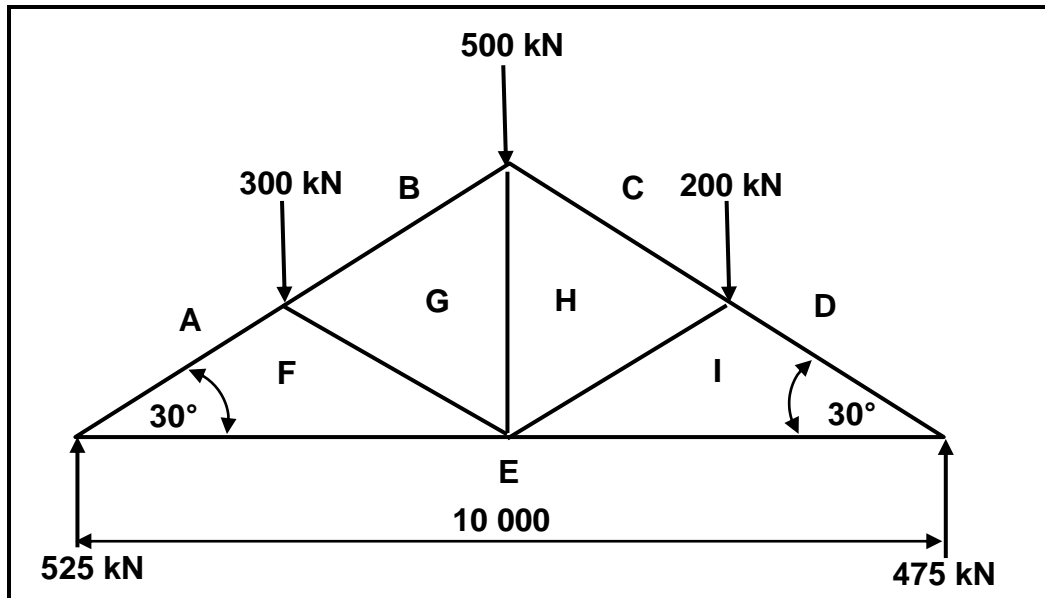

**FIGURE 7.1**

- 7.1.1 Determine graphically the force vector diagram of FIGURE 7.1 using scale 1 mm = 10 kN. (Redraw the space diagram and use scale 1 : 100.) (10)
- 7.1.2 Determine the magnitude and nature of the members, as shown in FIGURE 7.1. (18)

7.2 FIGURE 7.2 below shows a simply supported beam with TWO point loads.

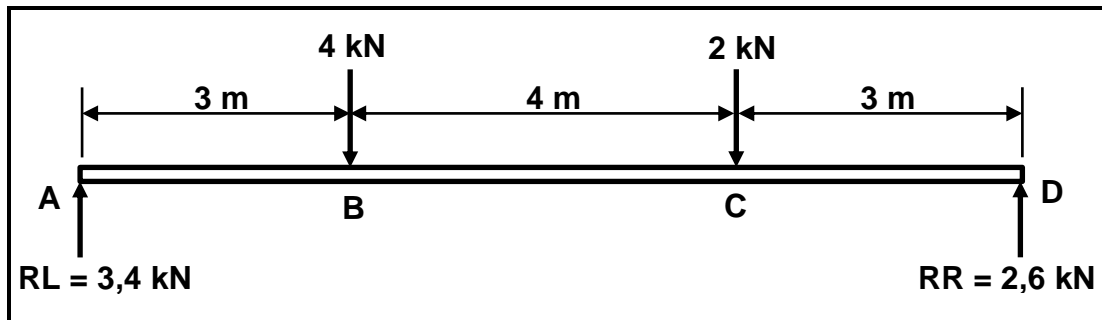

FIGURE 7.2

7.2.1 Calculate the bending moments at points **B**, **C** and **D**. (6)

7.2.2 Draw a shear force diagram. (3)

7.2.3 Draw a bending moment diagram.

SCALE: Space diagram: 1 : 100

Shear force diagram: 5 mm = 1 kN

Bending moment diagram: 5 mm = 1 kNm

Tolerance: ± 3 mm

(3)

7.3 A round steel bar with a cross-sectional area of  $80 \text{ mm}^2$  resists a maximum force of 8 kN when subjected to a tensile test. The safety factor is 4.

7.3.1 Calculate the maximum stress in the bar material. (3)

7.3.2 Calculate the safe working stress of the bar. (2)

[45]

**QUESTION 8: JOINING METHODS (INSPECTION OF WELDS) (SPECIFIC)**

- 8.1 State FOUR causes of spatter as a welding defect that occurs during the welding process. (4)
- 8.2 Briefly describe the effect of EACH of the following on the quality of a gas cut surface:
- 8.2.1 Nozzle too far from the surface (2)
- 8.2.2 Nozzle too close to the surface (2)
- 8.3 Describe TWO causes of EACH of the following weld defects:
- 8.3.1 Porosity (2)
- 8.3.2 Poor penetration (2)
- 8.4 Name TWO causes of cracks in the heat-affected zone (HAZ). (2)
- 8.5 Name THREE elements that should be inspected during the visual inspection of arc-welded joints. (3)
- 8.6 Describe the procedures to be followed when performing an ultrasonic test on a welded joint. (6)
- [23]**

**QUESTION 9: JOINING METHODS (STRESSES AND DISTORTION) (SPECIFIC)**

- 9.1 What is *residual stress*? (2)
- 9.2 Describe the effect of hot working on steel. (4)
- 9.3 Study FIGURE 9.3 below and answer the questions that follow.

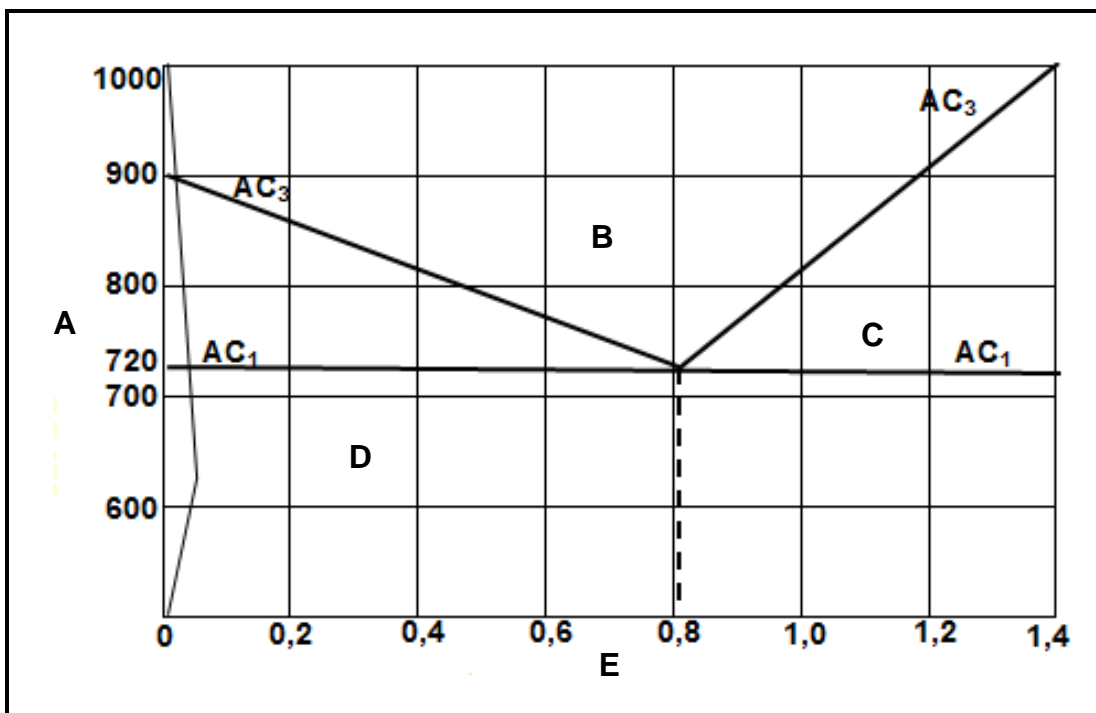

**FIGURE 9.3**

- 9.3.1 Identify the diagram in FIGURE 9.3. (1)
  - 9.3.2 Label A–E indicated on the diagram. (5)
  - 9.4 State TWO results when metal is cooled rapidly. (2)
  - 9.5 Name FOUR quenching media used for the heat treatment of steel. (4)
- [18]**

**QUESTION 10: MAINTENANCE (SPECIFIC)**

- 10.1 Name TWO types of maintenance procedures on machines in the welding workshop. (2)
- 10.2 Why is lock-out applied to machines during maintenance? (2)
- 10.3 State TWO rules to be observed before a machine start-up. (2)
- 10.4 Name THREE factors to be observed when selecting the cutting speed of a drilling machine. (3)

**[9]**



**QUESTION 11: TERMINOLOGY (DEVELOPMENT) (SPECIFIC)**

FIGURE 11 below shows a square-to-round transition piece.

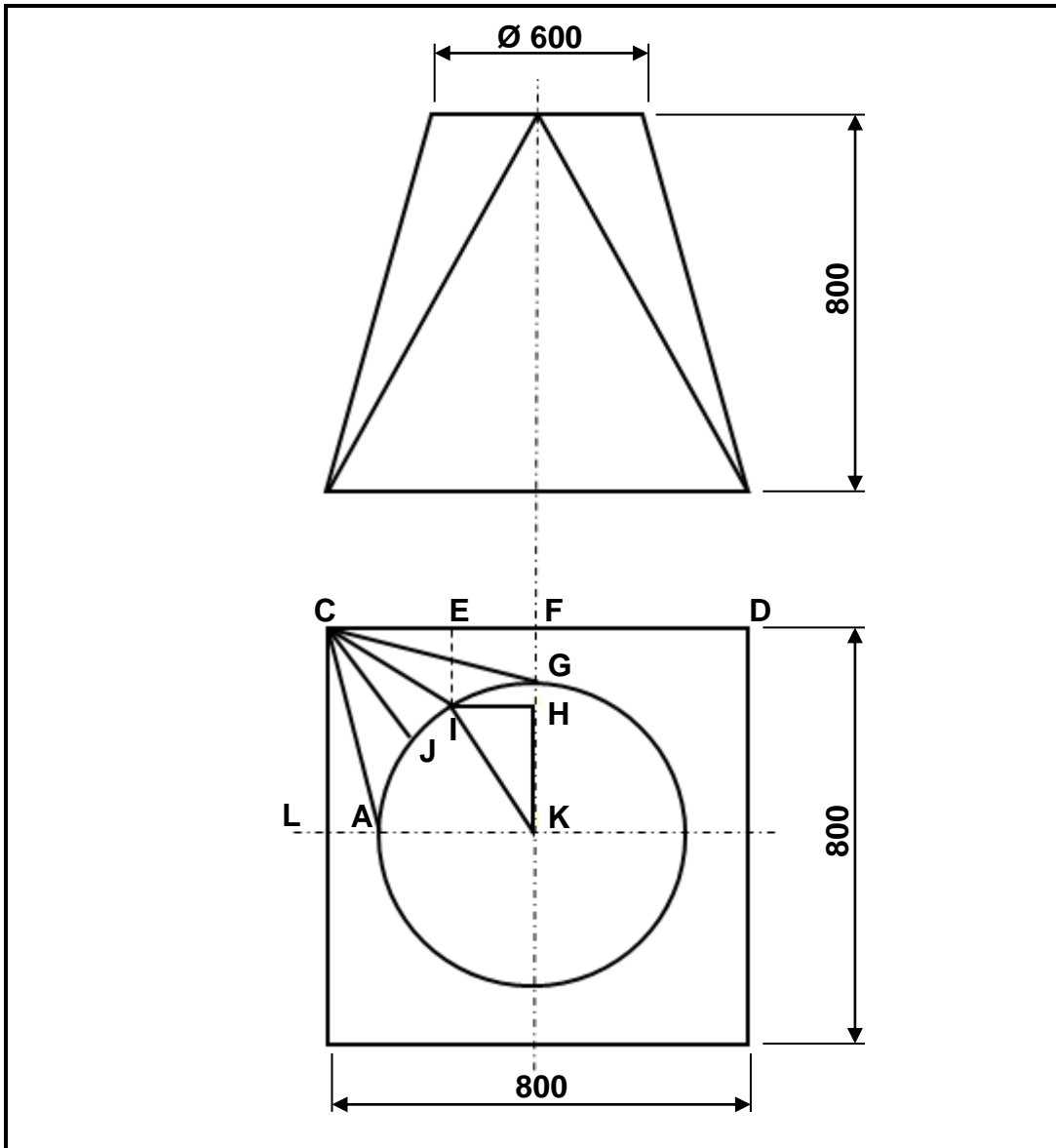

**FIGURE 11**

Calculate:

- 11.1 True length CG (7)
  - 11.2 True length CI (10)
  - 11.3 True length JI (3)
- [20]**

**TOTAL: 200**



## FORMULA SHEET FOR MECHANICAL TECHNOLOGY (WELDING AND METALWORK)

### 1. STRESS AND STRAIN

$$\text{Stress} = \frac{\text{Force}}{\text{Area}} \quad \text{or} \quad \sigma = \frac{F}{A}$$

$$\text{Strain} = \frac{\text{change in length}}{\text{original length}} \quad \text{or} \quad \varepsilon = \frac{\Delta L}{L}$$

$$\text{Young's modulus} = \frac{\text{stress}}{\text{strain}} \quad \text{or} \quad E = \frac{\sigma}{\varepsilon}$$

$$A_{\text{shaft}} = \frac{\pi d^2}{4}$$

$$A_{\text{pipe}} = \frac{\pi(D^2 - d^2)}{4}$$

### 2. PYTHAGORAS THEOREM AND TRIGONOMETRIC RATIOS

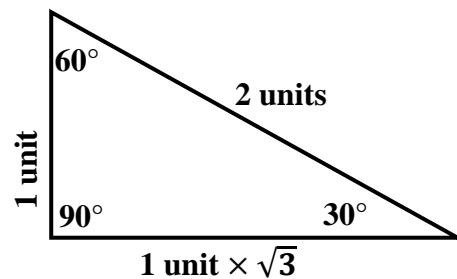
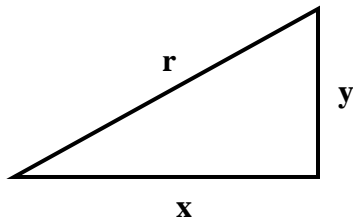

$$\sin \theta = \frac{y}{r}$$

$$\cos \theta = \frac{x}{r}$$

$$\tan \theta = \frac{y}{x}$$

$$r^2 = x^2 + y^2$$

### 3. TEMPLATES AND DEVELOPMENTS

Mean  $\emptyset$  = outside  $\emptyset$  – plate thickness      where  $\emptyset$  = diameter

Mean  $\emptyset$  = inside  $\emptyset$  + plate thickness

Mean circumference =  $\pi$  x mean  $\emptyset$