



# basic education

Department:  
Basic Education  
**REPUBLIC OF SOUTH AFRICA**

## **NATIONAL SENIOR CERTIFICATE**

**GRADE 12**

**MECHANICAL TECHNOLOGY: FITTING AND MACHINING**

**NOVEMBER 2019**

**MARKING GUIDELINES**

**MARKS: 200**

**These marking guidelines consist of 20 pages.**

**QUESTION 1: MULTIPLE-CHOICE (Generic)**

1.1	B ✓	(1)
1.2	C ✓	(1)
1.3	A ✓	(1)
1.4	C ✓	(1)
1.5	A ✓	(1)
1.6	C ✓	(1)
		<b>[6]</b>

**QUESTION 2: SAFETY (Generic)**

- 2.1 **Machine safety rule:**
- Know how to switch the machine off / emergency stop. ✓
  - Wear personal protective equipment (PPE). ✓
  - Know how to use the machine. ✓
  - Ensure that all guards are in place. ✓
  - No tools lying on the machine. ✓
  - Work piece is properly secured. ✓
  - Check the condition of the machine. ✓
  - Follow manufacture’s specifications before operating a machine. ✓
  - Operator must have authorization to working on a machine. ✓
  - Make sure the machine is not locked out. ✓
  - Ensure that the machine setup is correct and safe. ✓
  - Ensure that the machine area is clean and safe. ✓
- (Any 1 x 1) (1)
- 2.2 **Drill press safety precautions:**
- To prevent injuries. ✓
  - To improve accuracy. ✓
  - To prevent work piece rotating/moving. ✓
  - To prevent the drill bit from breaking. ✓
- (Any 1 x 1) (1)
- 2.3 **Hydraulic press safety rules:**
- Make sure the press is in a good working condition. ✓
  - Take notice of the pre-determined maximum pressure of the hydraulic press. ✓
  - Make sure the area around the press is clean and free of oil, grease and water. ✓
  - Ensure that the platform is rigid and square to the cylinder. ✓
  - Ensure that suitable jigs and prescribed equipment is available. ✓

- Check hydraulic pipes for leaks or cracks. ✓
- Check supporting pins are not worn out and fitted properly. ✓
- Check fluid levels. ✓
- Compressive force must be applied at 90° to the object. ✓
- Check cable and pulleys on the platform if equipped. ✓
- Correct PPE. ✓
- Pressure gauge must be checked and calibrated. ✓
- Ensure that all guards are in place. ✓

(Any 2 x 1) (2)

2.4 **Reasons for wearing surgical gloves:**

- To prevent HIV/AIDS or any blood related infections being transmitted. ✓
- To prevent contamination of the open wounds. ✓

(2)

2.5 **Safe handling of portable electrical equipment:**

- Ensure the electrical cord and plug, are in a good condition. ✓
- Ensure all safety guards are in place. ✓
- Ensure that the correct attachments (drill bits, blades etc.) are fixed in the correct way. ✓
- Do not force the machine/equipment. ✓
- Operate according to manufacturer instructions. ✓
- Avoid contact with water. ✓
- Keep the cable away from heat, oil, sharp edges and moving parts. ✓
- Make sure that the wires don't wrap around each other. ✓
- Avoid dropping the machine. ✓
- Check the condition of the equipment. ✓

(Any 2 x 1) (2)

2.6 **Responsibility of employer:**

- Provide and maintain working systems, work area, equipment and tools in a safe condition. ✓
- Eliminate or reduce any potential hazard. ✓
- Produce, handle, store and transport goods safely. ✓
- Ensure that every person employed complies with the requirements of this OHS Act. ✓
- Enforce measures if necessary in the interest of health and safety. ✓
- Appoint a person who is trained and who have the authority to ensure that the employee takes precautionary measures. ✓
- Inform employees of the hazards to his health and safety attached to any duty or work situation. ✓
- Provide first aid equipment. ✓

(Any 1 x 1) (1)

2.7 **Responsibility of employee:**

- Pay attention to their own and other people's health and safety. ✓
- Co-operate with the employer regarding the OHS Act. ✓
- Carry out a lawful order given to them. ✓
- Report any situation that is unsafe or unhealthy. ✓
- Report all incidents and accidents. ✓
- Not to interfere with any safety equipment or misuse such equipment. ✓
- Obey all safety rules. ✓

(Any 1 x 1)

(1)  
[10]

**QUESTION 3: MATERIAL (Generic)**

3.1 **Filing test:**

- Use the right ✓ filing skills. ✓
- File on the tip or edge ✓✓ of the metal.
- By applying chalk ✓ to the file surface. ✓

(Any 1 x 2)

(2)

3.2 **Purpose of heat treatment of steel:**

Heat treatment of steel is done to change ✓ the properties/grain structure ✓ of steel.

(2)

3.3 **Reasons for tempering hardened steel:**

- To reduce ✓ the brittleness ✓ caused by the hardening process.
- To relieve ✓ strain ✓ caused during hardening process.
- To increase ✓ the toughness ✓ of the steel.
- To give hardened work piece a more ✓ fine-grained structure. ✓

(Any 2 x 2)

(4)

3.4 **Heat treatment processes on steel:**

3.4.1 **Annealing:**

- The steel is heated to the prescribed temperature. ✓
- The steel is soaked at that temperature for the required time. ✓
- The steel is then cooled very slowly to produce maximum softness. ✓

(3)

3.4.2 **Hardening:**

- The steel is heated slightly higher than the upper critical temperature. (AC<sub>3</sub>) ✓
- The steel is soaked at that temperature for the required time. ✓
- The steel is then rapidly cooled by quenching in rapid cooling medium. ✓

(3)

[14]

**QUESTION 4: MULTIPLE-CHOICE QUESTIONS (Specific)**

- |      |       |             |
|------|-------|-------------|
| 4.1  | A ✓   | (1)         |
| 4.2  | D ✓   | (1)         |
| 4.3  | B/A ✓ | (1)         |
| 4.4  | A ✓   | (1)         |
| 4.5  | B/A ✓ | (1)         |
| 4.6  | B ✓   | (1)         |
| 4.7  | B ✓   | (1)         |
| 4.8  | A ✓   | (1)         |
| 4.9  | C ✓   | (1)         |
| 4.10 | B ✓   | (1)         |
| 4.11 | D ✓   | (1)         |
| 4.12 | B ✓   | (1)         |
| 4.13 | A ✓   | (1)         |
| 4.14 | B ✓   | (1)         |
|      |       | <b>[14]</b> |

**QUESTION 5: TERMINOLOGY (Lathe and Milling Machine) (Specific)**

**5.1 Taper turning:**

**5.1.1 Small diameter:**

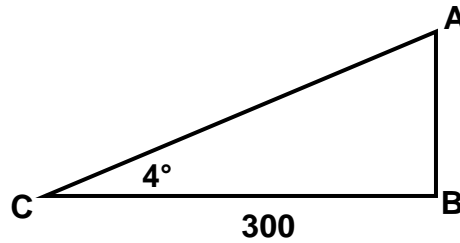

$$\tan \frac{\theta}{2} = \frac{AB}{300} \quad \checkmark$$

$$\begin{aligned} AB &= \tan 4^\circ \times 300 \\ &= 20,98 \text{ mm} \quad \checkmark \end{aligned}$$

$$\begin{aligned} d &= D - 2(AB) \quad \checkmark \\ &= 200 - 2(20,98) \quad \checkmark \\ &= 158,04 \text{ mm} \quad \checkmark \end{aligned}$$

**OR**

$$\tan \frac{\theta}{2} = \frac{D - d}{2L} \quad \checkmark$$

$$\tan 4^\circ = \frac{200 - d}{2(300)} \quad \checkmark$$

$$\begin{aligned} \tan 4^\circ \times 600 &= 200 - d \quad \checkmark \\ d &= 200 - (\tan 4^\circ \times 600) \quad \checkmark \\ d &= 158,04 \text{ mm} \quad \checkmark \end{aligned}$$

**OR**

$$\begin{aligned} d &= D - 2AB \quad \checkmark \\ &= 200 - 2(300 \times \tan 4^\circ) \quad \checkmark \checkmark \checkmark \\ &= 158,04 \text{ mm} \quad \checkmark \end{aligned}$$

(5)

5.1.2 **Setting over of tailstock:**

Setting over : 20,98 mm over 300 mm

Thus "X" mm over 400 mm

$$300"X" = 20,98 \times 400 \quad \checkmark$$

$$"X" = \frac{20,98 \times 400}{300} \quad \checkmark$$

$$"X" = 27,97 \text{ mm} \quad \checkmark$$

**OR**

$$\text{Set over} = \frac{L(D-d)}{2l} \quad \checkmark$$

$$= \frac{400(200 - 158,04)}{2(300)} \quad \checkmark$$

$$= 27,97 \text{ mm} \quad \checkmark$$

(3)

5.2 **Parallelkey:**

5.2.1 **Width:**

$$\begin{aligned} \text{Width} &= \frac{D}{4} \\ &= \frac{42}{4} \quad \checkmark \\ &= 10,5 \text{ mm} \quad \checkmark \end{aligned}$$

(2)

5.2.2 **Thickness:**

$$\begin{aligned} \text{Thickness} &= \frac{D}{6} \\ &= \frac{42}{6} \quad \checkmark \\ &= 7 \text{ mm} \quad \checkmark \end{aligned}$$

(2)

5.3 **Advantages of down cut milling:**

- A better finish is obtained. ✓
- Friction is reduced. ✓
- High speed cutting is possible. ✓
- Less power required. ✓
- Coolant is carried down to the teeth to where it is required. ✓
- Tends to force the work piece onto the machine table there for deeper cuts can be made. ✓
- Less vibration. ✓

**(Any 2 x 1)**

(2)

5.4 **Straddle milling:**

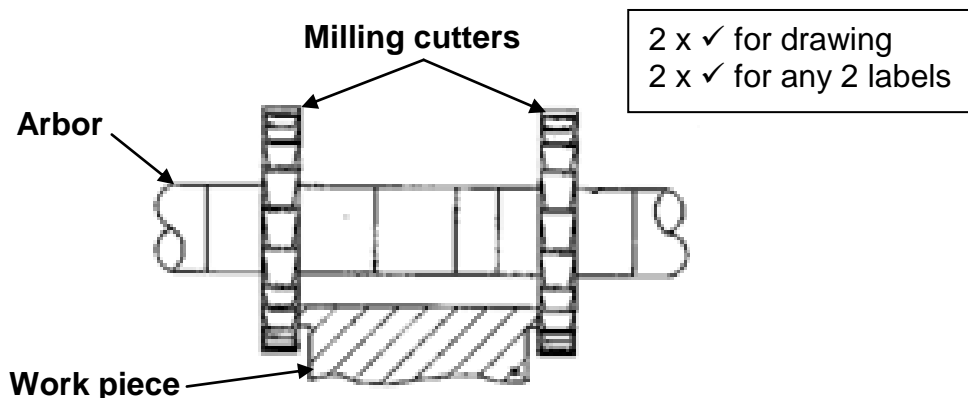

(4)  
 [18]

**QUESTION 6: TERMINOLOGY (Indexing) (Specific)**

6.1 **Spur gear terminology:**

6.1.1 **Module:**

$$\begin{aligned} \text{Module} &= \frac{\text{PCD}}{T} \\ &= \frac{126}{42} \quad \checkmark \\ &= 3 \quad \checkmark \end{aligned}$$

(2)

6.1.2 **Working depth:**

$$\begin{aligned} \text{WD} &= 2 \times m \quad \checkmark \\ &= 2 \times 3 \\ &= 6\text{mm} \quad \checkmark \end{aligned}$$

(2)

6.1.3 **Cutting depth:**

$$\begin{aligned} \text{Cutting depth} &= 2,157 \times m && = 2,25 \times m \\ &= 2,157 \times 3 \quad \checkmark && \text{or} && = 2,25 \times 3 \quad \checkmark \\ &= 6,47\text{mm} \quad \checkmark && && = 6,75\text{mm} \quad \checkmark \end{aligned}$$

(2)

6.2 **Angular indexing:**

$$\begin{aligned} \text{Indexing} &= \frac{n}{9^\circ} = \frac{34^\circ}{9^\circ} \quad \checkmark \\ &= 3 \frac{7}{9} \times \frac{6}{6} \quad \checkmark \\ &= 3 \frac{42}{54} \quad \checkmark \end{aligned}$$

3 full turns and 42 holes on the 54 hole circle. ✓

(4)



6.3 **Indexing:**

6.3.1 **Differential indexing:**

$$\begin{aligned} \text{Indexing} &= \frac{40}{N} \\ &= \frac{40}{121} && \notin \text{ not possible} \\ \text{Chosen divisions} &= \frac{40}{A} \\ &= \frac{40}{120} \quad \checkmark \\ &= \frac{1}{3} \times \frac{8}{8} \quad \checkmark \\ &= \frac{8}{24} \quad \checkmark \end{aligned}$$

- No full turns, 8 holes on the 24 hole circle. ✓
- OR
- No full turns, 10 holes on the 30 hole circle. ✓
- OR
- No full turns, 13 holes on the 39 hole circle. ✓
- OR
- No full turns, 14 holes on the 42 hole circle. ✓
- OR
- No full turns, 17 holes on the 51 hole circle. ✓
- OR
- No full turns, 18 holes on the 54 hole circle. ✓
- OR
- No full turns, 19 holes on the 57 hole circle. ✓
- OR
- No full turns, 22 holes on the 66 hole circle. ✓

(5)

6.3.2 **Change gears:**

$$\begin{aligned} \frac{Dr}{Dn} &= \frac{A-N}{A} \times \frac{40}{1} \\ &= \frac{120-121}{120} \times \frac{40}{1} \quad \checkmark \\ &= \frac{-1}{120} \times \frac{40}{1} \quad \checkmark \\ &= \frac{-40}{120} \\ &= \frac{-1}{3} \times \frac{24}{24} \quad \checkmark \\ \frac{Dr}{Dn} &= \frac{24}{72} \quad \checkmark \end{aligned}$$

(5)

6.4 Calculate distance Z between rollers:

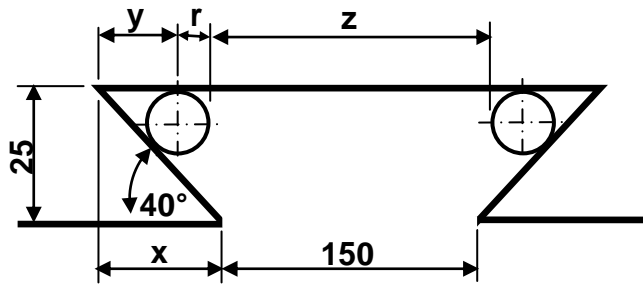

$$z = 150 + 2x - 2(y + r)$$

$$\tan 40^\circ = \frac{25}{x} \quad \checkmark$$

$$x = \frac{25}{\tan 40^\circ} = 29,79 \text{ mm} \quad \checkmark$$

$$r = \frac{d}{2} = \frac{10}{2} = 5 \text{ mm}$$

OR  $\checkmark$

$$\tan 20^\circ = \frac{r}{y} \quad \checkmark$$

$$y = \frac{5}{\tan 20^\circ} = 13,74 \text{ mm} \quad \checkmark$$

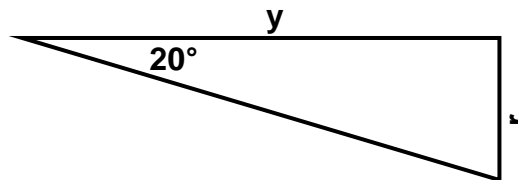
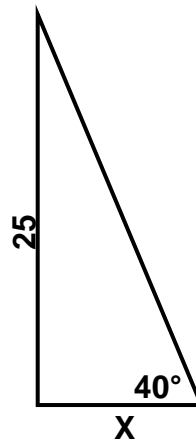

$$z = 150 + 2x - 2(y + r) \quad \checkmark$$

$$= 150 + 2(29,79) - 2(13,74 + 5) \quad \checkmark$$

$$= 150 + 59,58 - 37,48$$

$$= 172,1 \text{ mm} \quad \checkmark$$

(8)  
 [28]

**QUESTION 7: TOOLS AND EQUIPMENT (Specific)**

7.1

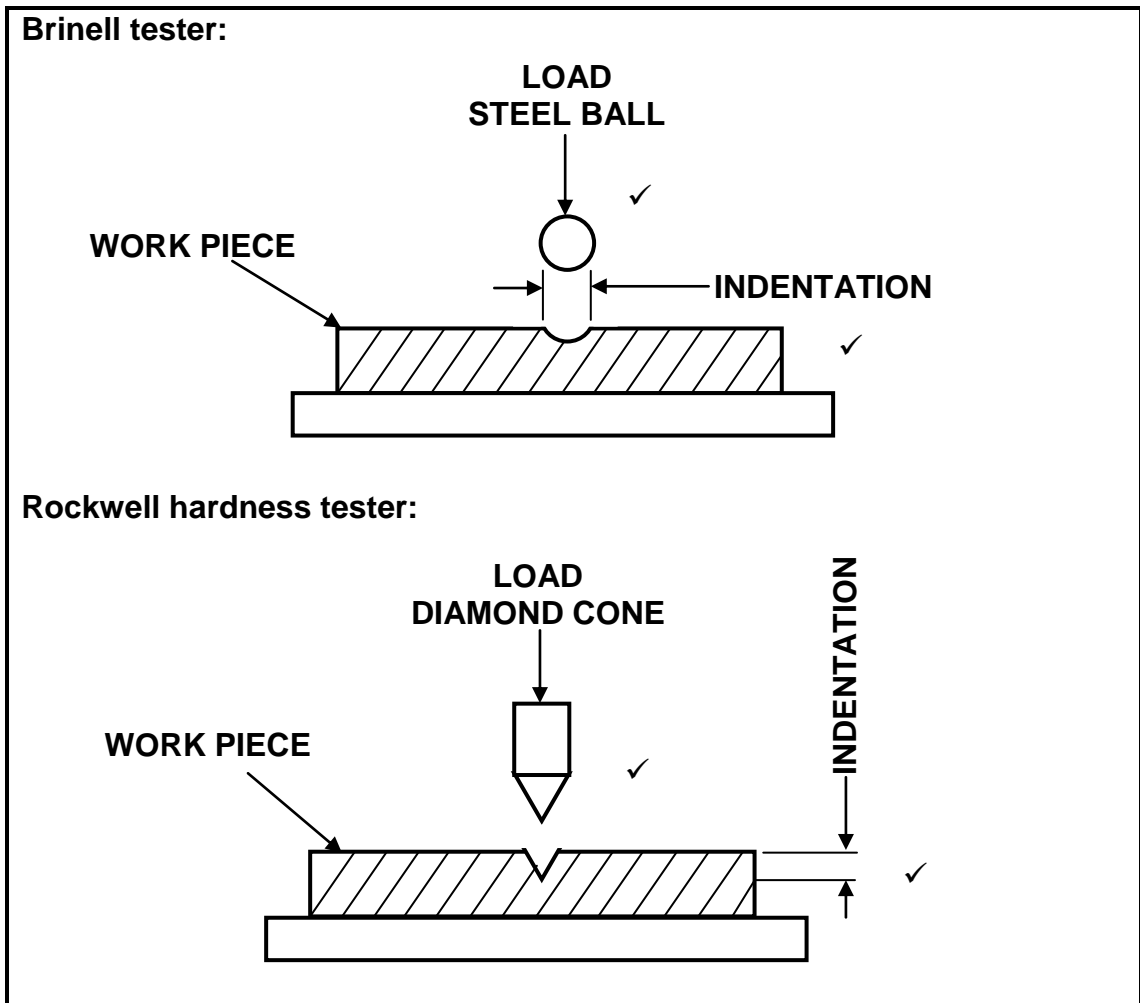

(4)

7.2

**Tensile test:**

- Tensile strength ✓
- Elasticity ✓
- Ductility ✓
- Plasticity ✓

(Any 2 x 1)

(2)

7.3

**Depth micro-meter reading:**

50,00 ✓  
16,00 ✓  
0,00 ✓  
0,33 ✓  
66,33 mm ✓

(5)

7.4

Screw thread ✓ micro meter ✓

(2)

[13]

**QUESTION 8: FORCES (Specific)**

8.1 **Equilibrant:**

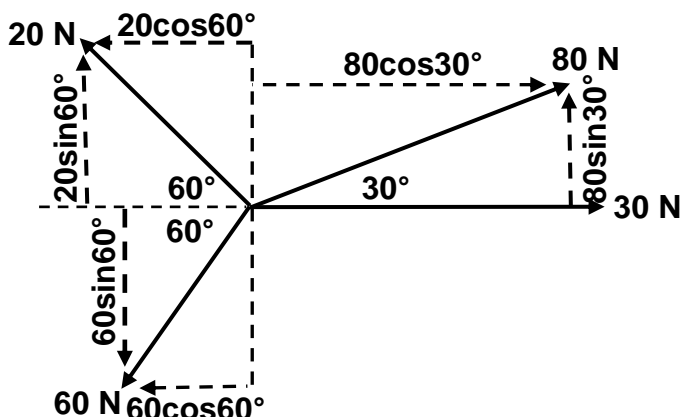

$$\begin{aligned} \sum HC &= 30 + 80\cos30^\circ - 20\cos60^\circ - 60\cos60^\circ \\ &= 30 + 69,28 - 10 - 30 \\ &= 59,28 \text{ N} \end{aligned}$$

$$\begin{aligned} \sum VC &= 20\sin60^\circ + 80\sin30^\circ - 60\sin60^\circ \\ &= 17,32 + 40 - 51,96 \\ &= 5,36 \text{ N} \end{aligned}$$

OR

HC	Magnitudes	VC	Magnitudes
30	30 ✓	20sin60°	17,32 ✓
80cos30°	69,28 ✓	80sin30°	40 ✓
-20cos60°	-10 ✓	-60sin60°	-51,96 ✓
-60cos60°	-30 ✓		
<b>TOTAL</b>	59,28 N ✓	<b>TOTAL</b>	5,36 N ✓

$$\begin{aligned} E^2 &= HC^2 + VC^2 \\ E &= \sqrt{59,28^2 + 5,36^2} \\ E &= 59,52 \text{ N} \end{aligned}$$

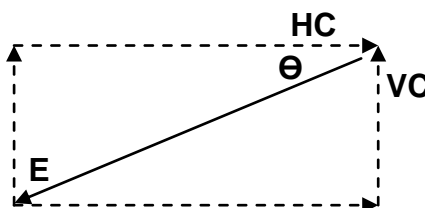

$$\begin{aligned} \tan\theta &= \frac{VC}{HC} \\ &= \frac{5,36}{59,28} \\ \theta &= 5,17^\circ \end{aligned}$$

E = 59,52 N at 5,17° (South from West) or  
 E = 59,52 N at 84,83° (West from South) or  
 E = 59,52 N at a bearing of 264,83°

8.2 **Moments:**

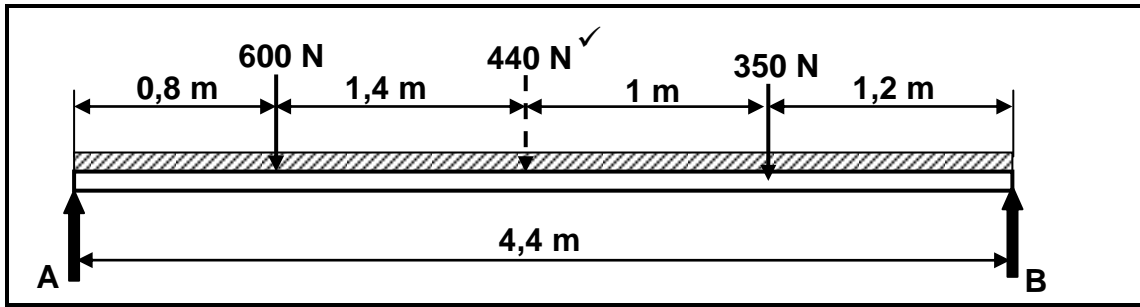

**Distributed load:**  
= 100 N/m × 4,4 m  
= 440 N ✓

**Calculate A:**

**Moments about B:**

$$\sum RHM = \sum LHM$$

$$(A \times 4,4) = (350 \times 1,2) + (440 \times 2,2) + (600 \times 3,6) \quad \checkmark$$

$$\frac{4,4A}{4,4} = \frac{3548}{4,4} \quad \checkmark$$

$$A = 806,36 \text{ N} \quad \checkmark$$

**Calculate B:**

**Moments about A:**

$$\sum LHM = \sum RHM$$

$$(B \times 4,4) = (600 \times 0,8) + (440 \times 2,2) + (350 \times 3,2) \quad \checkmark$$

$$\frac{4,4B}{4,4} = \frac{2568}{4,4} \quad \checkmark$$

$$B = 583,64 \text{ N} \quad \checkmark$$

(8)

8.3 **Stress-strain:**

8.3.1 Compressive stress ✓

(1)

8.3.2 **Stress:**

$$A = \frac{\pi(D^2 - d^2)}{4}$$
$$= \frac{\pi(0,04^2 - 0,025^2)}{4} \quad \checkmark$$
$$A = 0,77 \times 10^{-3} \text{m}^2 \quad \checkmark$$

$$\sigma = \frac{F}{A}$$
$$= \frac{600}{0,77 \times 10^{-3}} \quad \checkmark$$
$$\sigma = 779220,78 \text{ Pa or } \left. \begin{array}{l} = 0,78 \times 10^6 \text{ Pa or} \\ = 0,78 \text{ MPa} \end{array} \right\} \checkmark$$

(4)

8.3.3 **Change in length:**

$$E = \frac{\sigma}{\epsilon}$$
$$\epsilon = \frac{\sigma}{E} \quad \checkmark$$
$$= \frac{0,78 \times 10^6}{90 \times 10^9} \quad \checkmark$$
$$\epsilon = 8,66 \times 10^{-6} \quad \checkmark$$

$$\epsilon = \frac{\Delta l}{o l}$$
$$\Delta l = \epsilon \times o l \quad \checkmark$$
$$= (8,67 \times 10^{-6}) \times (100) \quad \checkmark$$
$$= 0,87 \times 10^{-3} \text{ mm} \quad \checkmark$$

(6)  
[33]

**QUESTION 9: MAINTENANCE (Specific)**

**9.1 Types of maintenance:**

- Preventative ✓
- Predictive ✓
- Reliable centred ✓

(3)

**9.2 Malfunctioning of belt drives:**

- Lubrication between belt and pulley causing belt slip. ✓
- Pulleys not properly secured to shafts. ✓
- Incorrect pulley alignment. ✓
- Overloading the system. ✓
- Incorrect belt tension. ✓
- Worn belts. ✓
- Faulty/damaged tensioner pulley. ✓
- Lack of maintenance. ✓

(Any 2 x 1) (2)

**9.3 Replace the chain on a chain drive system:**

- Release the tension on the chain and remove from sprocket. ✓
- Check the condition and alignment of the sprockets. ✓
- Fit the new specified chain and lubricate. ✓
- Apply adequate tension to the chain. ✓
- Check for proper operation. ✓

(5)

**9.4 Wear on a gear drive system:**

- Check and replenish of lubrication levels. ✓
- Ensuring the gears are properly secured to shafts. ✓
- Cleaning and replacement of oil filters. ✓
- Reporting excessive noise, wear, vibration and overheating for expert attention. ✓

(Any 2 x 1) (2)

**9.5 Material:**

**9.5.1 Nylon:**

- Bushes ✓
- Gears ✓
- Pulleys ✓
- Fishing line ✓
- Clothing ✓
- Sails ✓
- Ropes ✓
- Sport equipment ✓
- Powder coating ✓

(Any 1 x 1) (1)

9.5.2 **Glass fibre:**

- Used in boats ✓
- Motor vehicle bodies ✓
- Transparent roof sheets ✓
- Petrol tanks ✓
- Swimming pools ✓
- Furniture ✓
- Fruit and salad bowls ✓
- Ornaments ✓
- Fishing rods ✓
- Sporting equipment ✓

(Any 1 x 1) (1)

9.6 **Thermoplastic or Thermo hardened composites:**

9.6.1 **Teflon:**

Thermoplastic ✓

(1)

9.6.2 **Bakelite:**

Thermo hardened / Thermo setting ✓

(1)

9.7 **Coefficient of friction:**

- Contact pressure ✓
- Surface roughness ✓
- Temperature ✓
- Sliding velocity ✓
- Type (amount) of lubricant ✓
- Type of material ✓

(Any 2 x 1) (2)

[18]



**QUESTION 10: JOINING METHODS (Specific)**

**10.1 Screw thread diameters:**

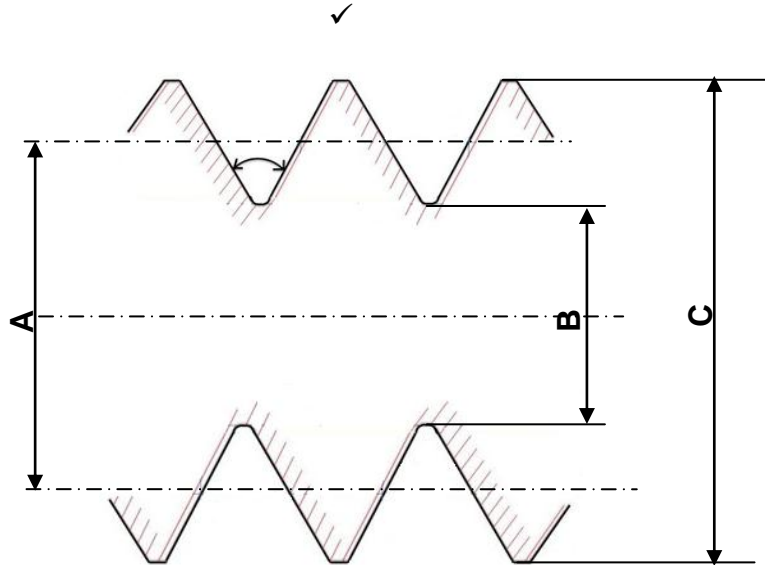

A = Pitch diameter/Effective diameter ✓

B = Minor diameter/Root diameter ✓

C = Major diameter/Crest diameter/Outside diameter/Nominal diameter/Basic diameter ✓

(4)

**10.2 Lead of a screw thread:**

The lead is the distance a thread ✓ will move axially ✓ in one full revolution. ✓

(3)

**10.3 Square screw thread:**

**10.3.1 Screw thread lead:**

Lead = pitch × no of starts

$$= 4 \times 3 \quad \checkmark$$

$$= 12 \text{ mm} \quad \checkmark$$

(2)

**10.3.2 Mean/pitch circumference:**

$$\text{Mean/pitch circumference} = \pi \left( \text{OD} - \frac{P}{2} \right) \quad \checkmark$$

$$= \pi \left( 68 - \frac{4}{2} \right) \quad \checkmark$$

$$= 207,35 \text{ mm} \quad \checkmark$$

(3)

10.3.3 **Helix angle:**

$$\begin{aligned} \text{Helix angle } \tan\theta &= \frac{\text{lead}}{\text{mean/pitch circumference}} \\ &= \frac{12}{207,35} \quad \checkmark \\ \theta &= 3,31^\circ \quad \checkmark \end{aligned}$$

(2)

10.3.4 **Leading angle:**

$$\begin{aligned} \text{Leading tool angle} &= 90^\circ - (\text{helix angle} + \text{clearance angle}) \\ &= 90^\circ - (3,31^\circ + 3^\circ) \quad \checkmark \\ &= 83,69^\circ \quad \checkmark \end{aligned}$$

(2)

10.3.5 **Following angle:**

$$\begin{aligned} \text{Following tool angle} &= 90^\circ + (\text{helix angle} - \text{clearance angle}) \\ &= 90^\circ + (3,31^\circ - 3^\circ) \quad \checkmark \\ &= 90,31^\circ \quad \checkmark \end{aligned}$$

(2)

[18]

**QUESTION 11: SYSTEMS AND CONTROL (Drive Systems) (Specific)**

11.1 **Advantages of a gear drive:**

- Compact assembly ✓
- More power can be transmitted/Stronger ✓
- No slip occurs ✓
- Less maintenance ✓

(Any 2 x 1)

(2)

11.2 **Hydraulics:**

11.2.1 **Fluid pressure:**

$$\begin{aligned} A_B &= \frac{\pi D_B^2}{4} \\ &= \frac{\pi(0,2)^2}{4} \quad \checkmark \\ &= 31,42 \times 10^{-3} \text{ m}^2 \quad \checkmark \end{aligned}$$

$$\begin{aligned} P &= \frac{F_B}{A_B} \\ &= \frac{15 \times 10^3}{31,42 \times 10^{-3}} \quad \checkmark \\ &= 477,40 \times 10^3 \text{ Pa} \quad \checkmark \\ &= 477,40 \text{ kPa} \quad \checkmark \end{aligned}$$

(5)

11.2.2 Distance 'X':

$$A_A = \frac{\pi D_A^2}{4}$$

$$= \frac{\pi (0,075)^2}{4} \quad \checkmark$$

$$= 4,42 \times 10^{-3} \text{m}^2 \quad \checkmark$$

$$V_B = V_A$$

$$A_B \times L_B = A_A \times L_A \quad \checkmark$$

$$L_B = \frac{A_A \times L_A}{A_B} \quad \checkmark$$

$$= \frac{(4,42 \times 10^{-3}) \times (0,12)}{(31,42 \times 10^{-3})} \quad \checkmark$$

$$= 16,88 \times 10^{-3} \text{ m}$$

$$= 16,88 \text{ mm} \quad \checkmark$$

(6)

11.3 Advantages of pneumatics:

- Compressed air is easy and cheap to generate. ✓
- Leakages are not messy – no oil spills. ✓
- Positive and negative pressure can be generated. ✓
- More compact. ✓
- Easily maintain due to fewer working parts. ✓

(Any 2 x 1) (2)

11.4 Belt-drive system:

11.4.1

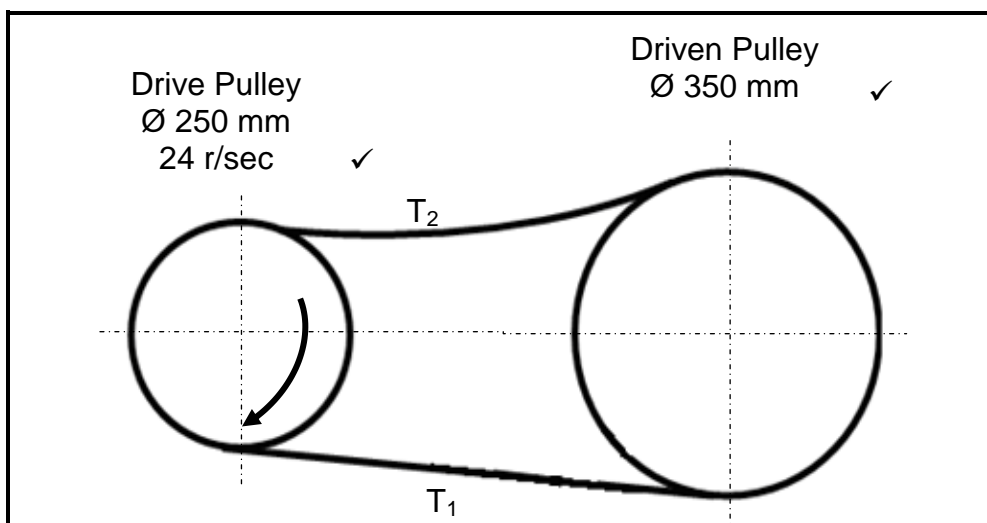

(2)

11.4.2 **Belt speed:**  
 $v = \pi Dn$  ✓  
 $= \pi \times 0,25 \times 24$  ✓  
 $v = 18,85 \text{ m.s}^{-1}$  OR  $18,85 \text{ m/s}$  ✓ (3)

11.4.3 **Power transmitted:**  
 $P = (T_1 - T_2)v$  ✓  $P = (T_1 - T_2)\pi Dn$  ✓  
 $= (300 - 120)18,85$  ✓  $= (300 - 120)\pi \times 0,25 \times 24$  ✓  
 $= 180 \times 18,85$  ✓  $= 180 \times 18,85$  ✓  
 $= 3393 \text{ Watt}$  ✓  $= 3393 \text{ Watt}$  ✓  
 $= 3,39 \text{ kW}$  ✓ OR  $= 3,39 \text{ kW}$  ✓ (4)

11.5 **Gear drive system:**  
**Number of teeth on gear C:**

$$\frac{N_A}{N_D} = \frac{T_B \times T_D}{T_A \times T_C} \quad \checkmark$$

$$N_A = \frac{T_B \times T_D \times N_D}{T_A \times T_C} \quad \checkmark$$

$$= \frac{80 \times 60 \times 120}{30 \times 40} \quad \checkmark$$

$$= 480 \text{ r/min} \quad \checkmark$$

OR

$$N_C \times T_C = N_D \times T_D$$

$$N_C = \frac{N_D \times T_D}{T_C} \quad \checkmark$$

$$= \frac{120 \times 60}{40} \quad \checkmark$$

$$= 180 \text{ r/min} \quad \checkmark$$

$$N_A \times T_A = N_B \times T_B$$

$$N_A = \frac{N_B \times T_B}{T_A} \quad \checkmark$$

$$= \frac{180 \times 80}{30} \quad \checkmark$$

$$= 480 \text{ r/min} \quad \checkmark$$

**TOTAL:** (4)

**[28]**  
**200**