

Confidential



basic education

Department:
Basic Education
REPUBLIC OF SOUTH AFRICA

SENIOR CERTIFICATE EXAMINATIONS/ NATIONAL SENIOR CERTIFICATE EXAMINATIONS

ELECTRICAL TECHNOLOGY: POWER SYSTEMS

MAY/JUNE 2024

MARKS: 200

TIME: 3 hours

This question paper consists of 18 pages and a 2-page formula sheet.



INSTRUCTIONS AND INFORMATION

1. This question paper consists of SEVEN questions.
2. Answer ALL the questions.
3. Sketches and diagrams must be large, neat and FULLY LABELLED.
4. Show ALL calculations and round off answers correctly to TWO decimal places.
5. Number the answers correctly according to the numbering system used in this question paper.
6. You may use a non-programmable calculator.
7. Calculations must include:
 - 7.1 Formulae and manipulations where needed
 - 7.2 Correct replacement of values
 - 7.3 Correct answer and relevant units where applicable
8. A formula sheet is attached at the end of this question paper.
9. Write neatly and legibly.



QUESTION 1: MULTIPLE-CHOICE QUESTIONS

Various options are provided as possible answers to the following questions. Choose the answer and write only the letter (A–D) next to the question numbers (1.1 to 1.15) in the ANSWER BOOK, e.g. 1.16 D.

- 1.1 A burn must be treated by ...
- A covering the burnt area with butter.
 - B putting ice on the burn wound.
 - C puncturing the blisters.
 - D running cold water over the burnt area until the pain reduces. (1)
- 1.2 The power in an inductor is ...
- A apparent power.
 - B active power.
 - C reactive power.
 - D true power. (1)
- 1.3 A parallel RLC circuit is more capacitive when ...
- A $X_C > X_L$
 - B $R = Z$
 - C $I_C > I_L$
 - D $V_C > V_L$ (1)
- 1.4 An increase in resistance of a parallel resonant circuit will cause the total current to ...
- A double.
 - B decrease.
 - C increase.
 - D be zero. (1)
- 1.5 Efficiency of electrical systems in industries with large inductive loads cause ...
- A high power factor with current leading the voltage.
 - B low power factor with current leading the voltage.
 - C high power factor with current lagging the voltage.
 - D low power factor with current lagging the voltage. (1)
- 1.6 The line current of a star connected system is 10 A. The phase current will be ...
- A 30 A
 - B 17,32 A
 - C 10 A
 - D 5,77 A (1)



- 1.7 The apparent power of a delta-connected three-phase system with a line current of 5 A and phase voltage of 300 V is ...
- A 2 598,08 VA
 - B 1 500 VA
 - C 2 598,08 VAR
 - D 1 500 VAR
- (1)
- 1.8 The following statement describes a core-type transformer:
- A The core hides the major part of the windings
 - B Double magnetic circuit
 - C Single magnetic circuit
 - D The core has five limbs
- (1)
- 1.9 The factors that can contribute to excessive heating in transformers is/are ...
- A constant overloading.
 - B insufficient ventilation.
 - C transformer oil may be insufficient.
 - D All the above-mentioned.
- (1)
- 1.10 A continuity test on the windings of a three-phase induction motor is carried out between ... in the terminal box when the connectors between windings have been removed.
- A U_1 and V_1
 - B V_1 and earth
 - C U_1 and W_1
 - D U_1 and U_2
- (1)
- 1.11 The ... of a contactor is/are wired into the main/power circuit with reference to motor starters.
- A main contacts
 - B auxiliary contacts
 - C zero-volt coil
 - D A1 and A2 terminals
- (1)
- 1.12 The ratio of the output power to the input power of a three-phase motor is known as ...
- A power factor.
 - B efficiency.
 - C slip.
 - D apparent power.
- (1)



- 1.13 ... proximity sensors are used only to detect the presence of metal objects.
- A Capacitive
 - B Ultrasonic
 - C Photo-electric
 - D Inductive
- (1)
- 1.14 ... are bits in the PLC's virtual storage memory which can be used to hold data and behave as relays.
- A Latching contacts
 - B Markers or flags
 - C Timers
 - D Strain gauges
- (1)
- 1.15 The purpose of a braking resistor in the regenerative braking process is to ...
- A store the excess energy in its electrostatic field.
 - B limit the amount of excess current.
 - C dissipate the excess energy in the form of heat.
 - D store the excess energy in its electromagnetic field.
- (1)
[15]

QUESTION 2: OCCUPATIONAL HEALTH AND SAFETY

- 2.1 State TWO unsafe acts that would be regarded as dangerous practices by a user when operating machinery. (2)
- 2.2 With reference to the Occupational Health and Safety Act, 1993 (Act 85 of 1993), give TWO examples that are considered to be offences when reporting to the safety inspector. (2)
- 2.3 Discuss the general duties that manufacturers perform when designing or manufacturing articles used at work. (2)
- 2.4 Define a *non-critical incident*. (2)
- 2.5 Describe a dangerous effect that a current of 200 mA has on the human body. (2)
[10]



QUESTION 3: RLC CIRCUITS

- 3.1 Explain the term *reactance* with reference to an alternating current circuit. (2)
- 3.2 FIGURE 3.2 below shows the circuit diagram, waveforms and a partial phasor diagram of the voltages in a RLC circuit that is connected to an AC supply. Study the diagrams below and answer the questions that follow.

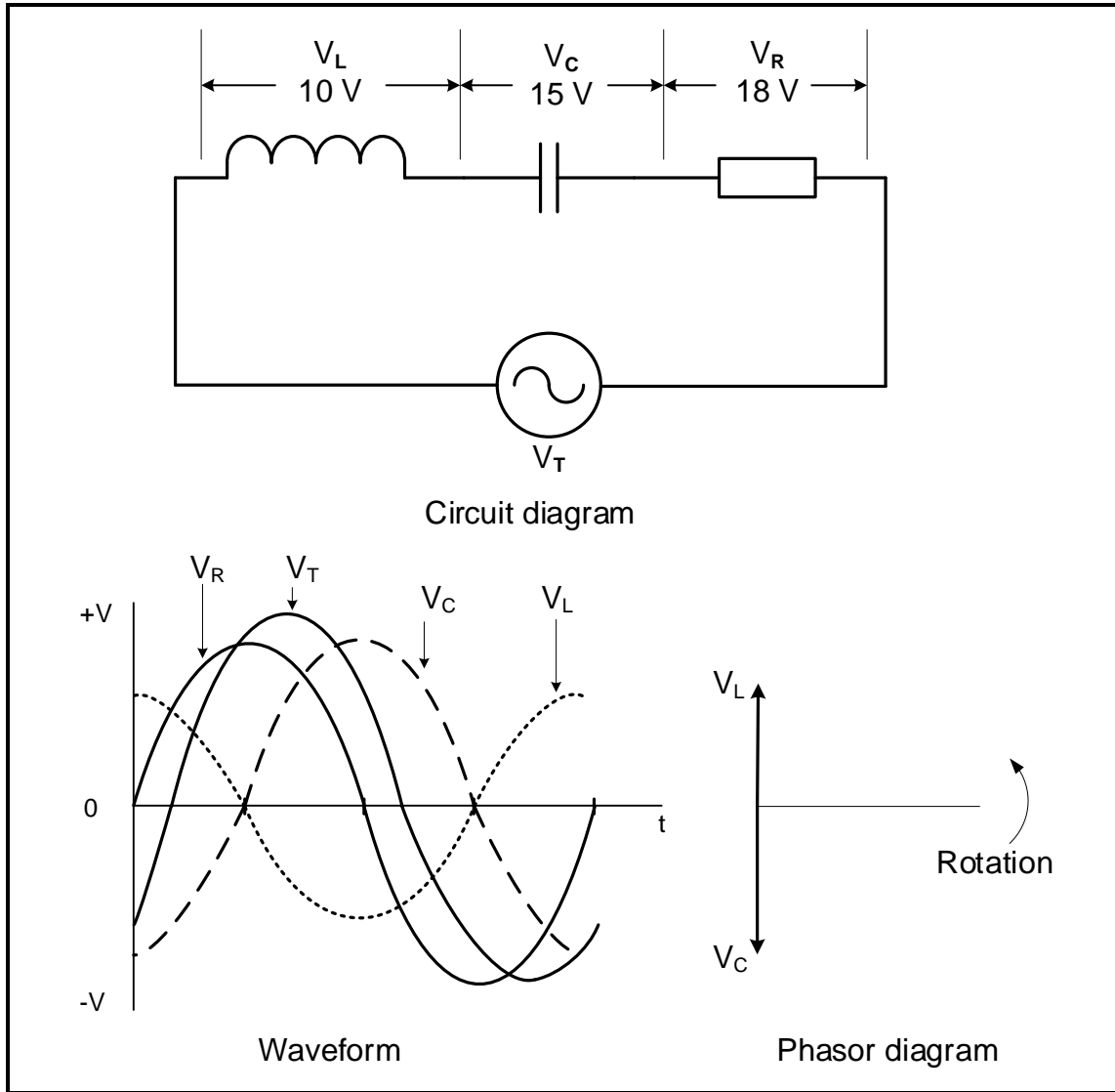

FIGURE 3.2: RLC CIRCUIT, WAVEFORM AND PHASOR

Given:

$$\begin{aligned}
 V_R &= 18 \text{ V} \\
 V_L &= 10 \text{ V} \\
 V_C &= 15 \text{ V}
 \end{aligned}$$

- 3.2.1 State whether the circuit is predominantly inductive or capacitive. Motivate your answer. (2)
- 3.2.2 Calculate the supply voltage. (3)



- 3.2.3 Calculate the phase angle. (3)
- 3.2.4 Redraw and complete the phasor diagram in the ANSWER BOOK. (3)
- 3.2.5 Explain why it could be assumed that the supply current is leading the supply voltage. (2)

3.3 Refer to FIGURE 3.3 below and answer the questions that follow.

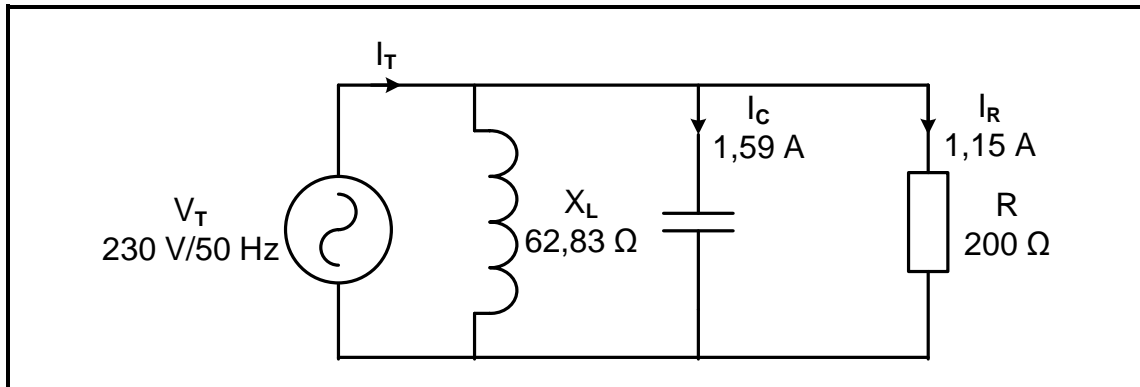

FIGURE 3.3: RLC PARALLEL CIRCUIT

Given:

$$\begin{aligned} X_L &= 62,83 \Omega \\ R &= 200 \Omega \\ I_R &= 1,15 \text{ A} \\ I_C &= 1,59 \text{ A} \\ V_T &= 230 \text{ V} \\ f &= 50 \text{ Hz} \end{aligned}$$

Calculate the:

- 3.3.1 Current flow through the inductor (3)
- 3.3.2 Total current flow (3)
- 3.3.3 Power factor (3)
- 3.3.4 Value of capacitance that would cause resonance when the frequency and inductor remain constant (4)



3.4 FIGURE 3.4 below shows the current vs frequency response curves of a series resonant circuit with a variable resistor. The inductive reactance of the circuit is $2\,000\ \Omega$ at resonance and each response curve is for a different resistance value.

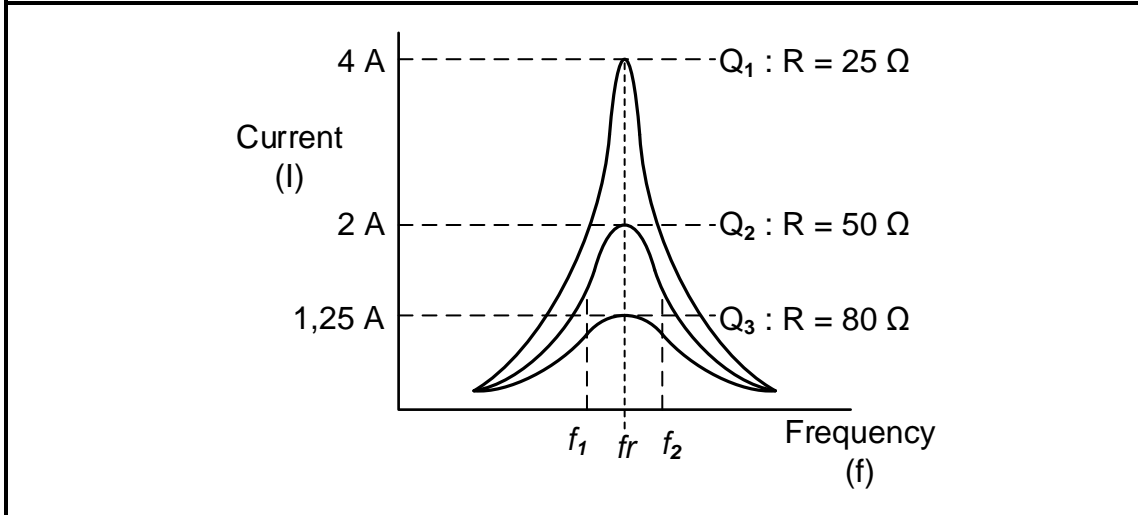

FIGURE 3.4: FREQUENCY RESPONSE

Given:

$X_L = 2\,000\ \Omega$

- 3.4.1 State how a decrease in resistance affects the Q-factor of the circuit. (1)
 - 3.4.2 Calculate the Q factor when $R = 50\ \Omega$. (3)
 - 3.4.3 Calculate the resonant frequency when $f_1 = 1\,200\ \text{Hz}$ and $f_2 = 2\,100\ \text{Hz}$. (3)
- [35]**



QUESTION 4: THREE-PHASE AC GENERATION

4.1 FIGURE 4.1 below shows a block diagram of the national power grid in South Africa. Answer the questions that follow.

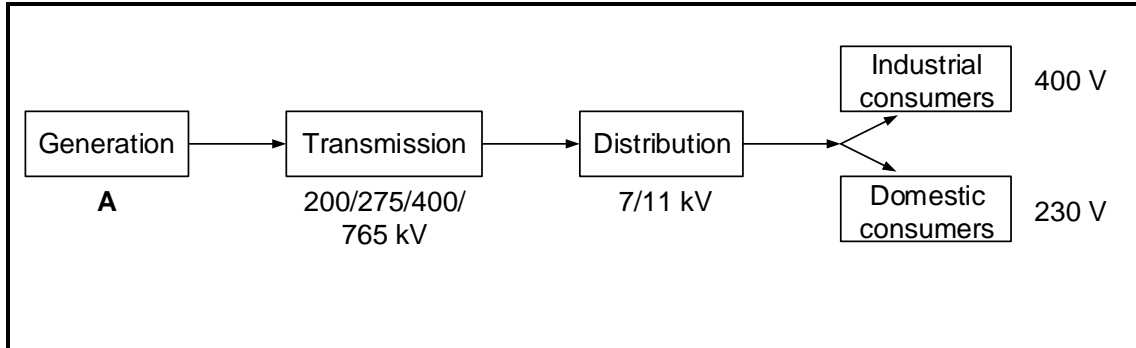

FIGURE 4.1: NATIONAL POWER GRID

- 4.1.1 State the voltage generated at block **A**. (1)
- 4.1.2 Name the standard international colour code for a three-phase system with reference to each phase. (3)
- 4.1.3 Briefly describe the national grid. (2)
- 4.1.4 Explain why the transmission of electricity is done at such high voltages. (2)
- 4.1.5 Explain how the voltage for an industrial consumer is different from the voltage for a domestic consumer. (2)
- 4.2 Give TWO reasons why an industrial consumer would prefer a three-phase supply over a single-phase supply. (2)
- 4.3 A 180 kW three-phase delta-connected load is powered by a 200 kVA generator. The line voltage is 400 V. Answer the questions that follow.
Given:
 $S = 200 \text{ kVA}$
 $V_L = 400 \text{ V}$
 $P = 180 \text{ kW}$
 Calculate the:
 - 4.3.1 Line current (3)
 - 4.3.2 Phase current (3)
 - 4.3.3 Power factor (3)
 - 4.3.4 Reactive power (5)



4.4 FIGURE 4.4 below shows the result of power factor correction in a three-phase system. The supply voltage and load remained the same throughout the process. S_1 and Q_1 are original values with S_2 and Q_2 the values after power factor correction was done.

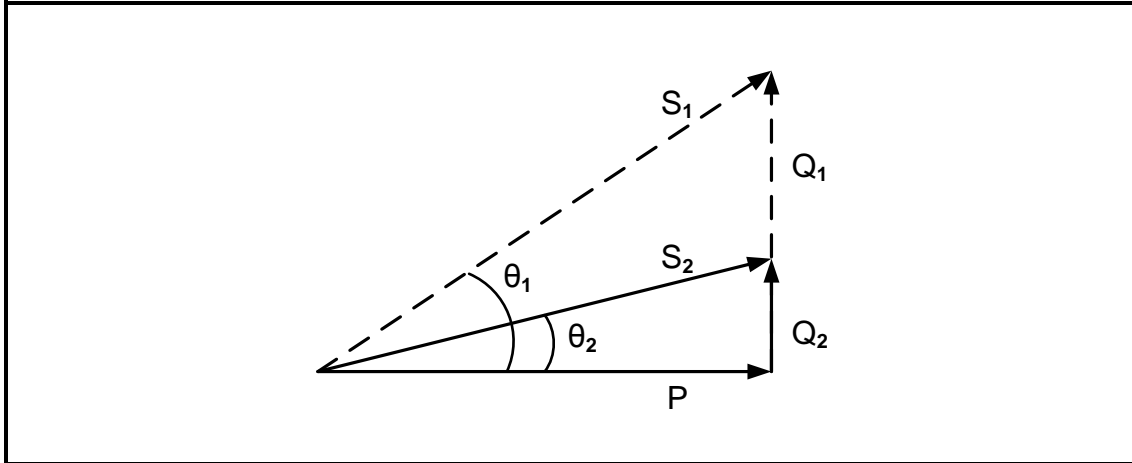

FIGURE 4.4: POWER FACTOR CORRECTION

- 4.4.1 State where power factor correcting devices may be installed. (1)
- 4.4.2 Identify ONE improvement with reference to FIGURE 4.4 above. (1)
- 4.4.3 Explain how power factor correction affected the current drawn from the supply by comparing the power triangle before and after power factor correction. (2)
- 4.5 Differentiate between *wattmeters* and *energy meters* with reference to their applications. (2)
- 4.6 Two wattmeters are used to measure the total power of a three-phase system. If the total power is 3,5 kW and the reading on meter 1 is displayed as 1 300 W, determine the reading on meter 2. (3)

[35]



QUESTION 5: THREE-PHASE TRANSFORMERS

5.1 Refer to FIGURE 5.1 below and answer the questions that follow.

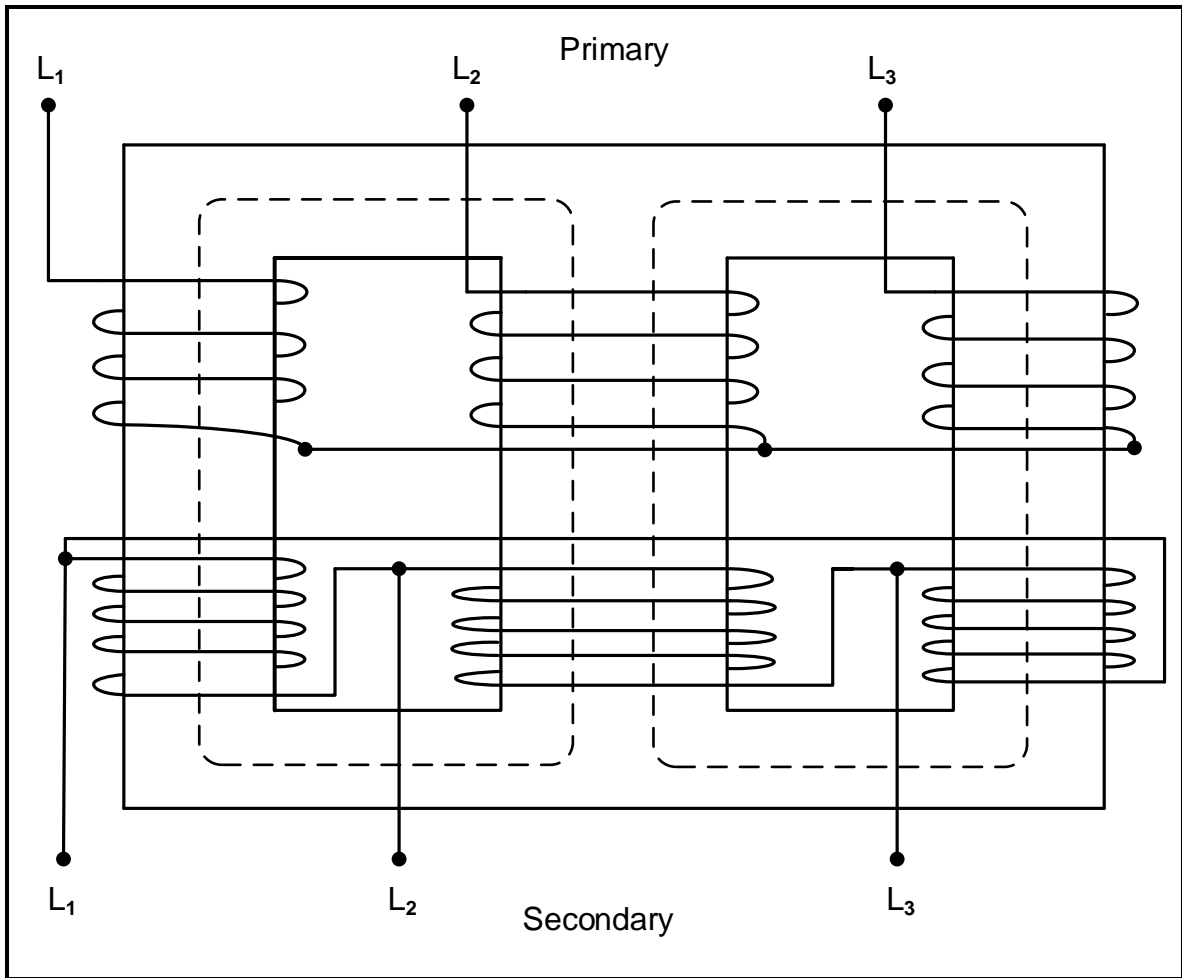

FIGURE 5.1: THREE-PHASE TRANSFORMER

5.1.1 State whether this is a core-type or shell-type three-phase transformer. (1)

5.1.2 State ONE advantage of a shell-type transformer over a core-type transformer. (1)

5.1.3 State the configuration of the primary and secondary windings in FIGURE 5.1 above. (2)

5.1.4 Briefly describe the principle of operation of the three-phase transformer in FIGURE 5.1 above. (4)

5.2 With reference to transformers, answer the following questions.

5.2.1 Describe the effect that an increase in the load will have on the primary current of a transformer. (2)

5.2.2 Name ONE function of the dielectric oil used in transformers. (1)



- 5.2.3 Name TWO types of losses other than copper losses that occur in transformers. (2)
- 5.2.4 Name and explain TWO cooling methods used for dry transformers. (4)
- 5.2.5 Compare conductor sizes between a single-phase transformer and a three-phase transformer for the same power rating. (2)

5.3 FIGURE 5.3 below shows a 300 kW delta-connected load with a power factor of 0,87 that is connected to a delta-star transformer. The primary and secondary line voltages of the transformer are 8 kV and 600 V respectively. Assume that the transformer is 100% efficient. Answer the questions that follow.

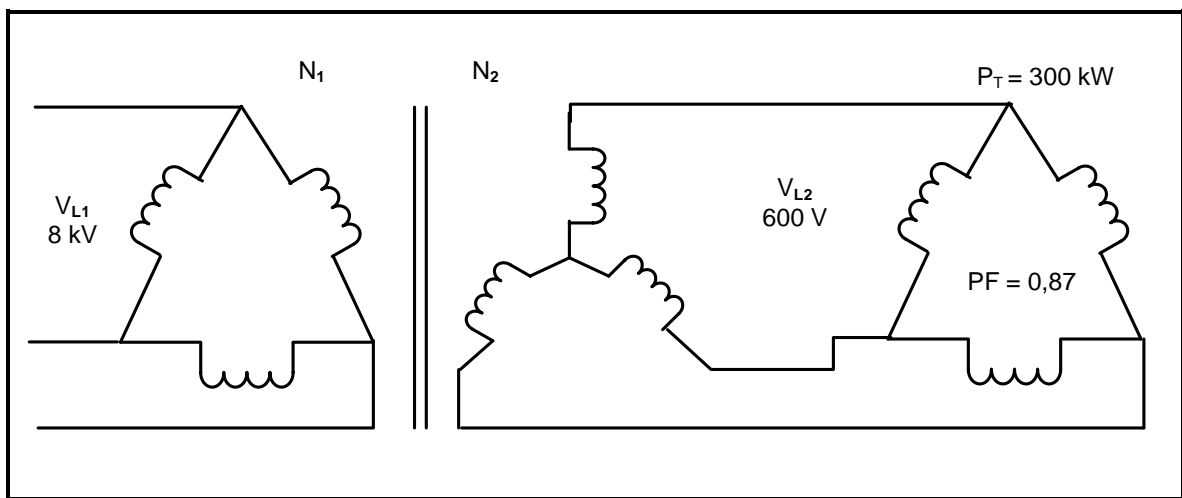

FIGURE 5.3: THREE-PHASE DELTA-STAR CONNECTED TRANSFORMER

Given:

- $V_{L1} = 8 \text{ kV}$
- $V_{L2} = 600 \text{ V}$
- $P_T = 300 \text{ kW}$
- $pf = 0,87$

Calculate the following:

- 5.3.1 Line current of the load (3)
 - 5.3.2 Phase current of the load (3)
 - 5.3.3 Primary line current (3)
- 5.4 Protection devices used with three-phase transformers are categorised in two categories, relay and switches. Name TWO protection relays used in three-phase transformers (2)

[30]



QUESTION 6: THREE-PHASE MOTORS AND STARTERS

- 6.1 Name TWO rotating parts of a three-phase induction motor. (2)
- 6.2 FIGURE 6.2 below shows how the coils of a three-phase induction motor are placed in a stator. Answer the questions that follow.

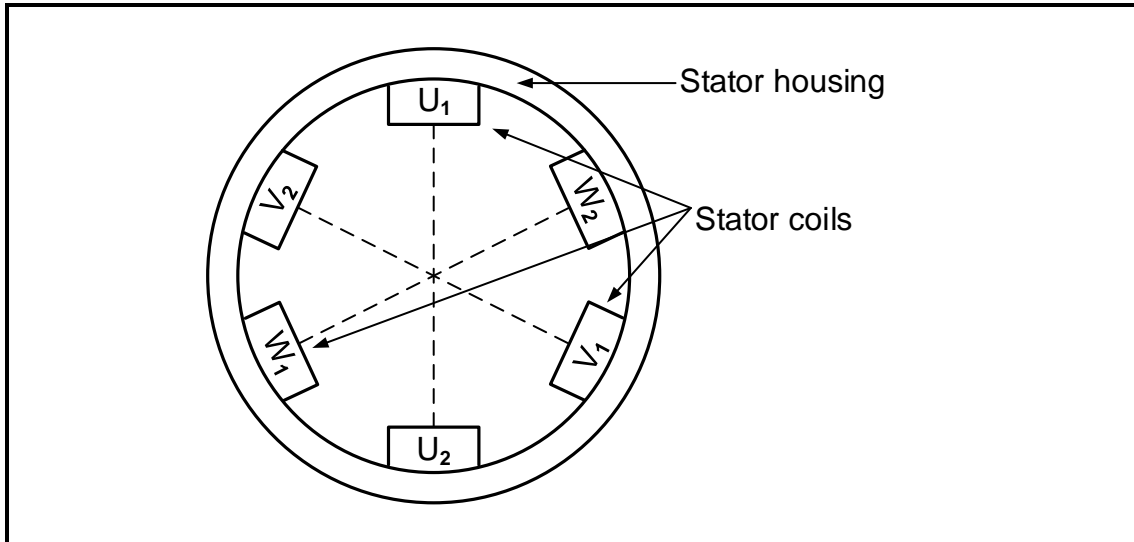

FIGURE 6.2: THREE-PHASE STATOR

- 6.2.1 Determine the angle between coil U and coil V. (1)
- 6.2.2 Explain how a rotating magnetic field is created when a three-phase supply is connected to the stator windings (4)
- 6.2.3 State why a squirrel cage is less of a fire hazard (explosion proof). (1)
- 6.3 A three-phase induction motor has 12 poles. When operating from a 50 Hz supply, the slip is 5%.

Given:

- f = 50 Hz
- p = 2
- slip = 5%

Calculate the following:

- 6.3.1 Synchronous speed (3)
- 6.3.2 Rotor speed (3)



6.4 The following information is available on a delta-connected three-phase induction motor:

- Input current = 20 A
- Supply voltage = 400 V
- Input power = 11,75 kW
- Total losses = 1 750 W

Calculate the:

- 6.4.1 Efficiency (3)
- 6.4.2 Apparent power (3)
- 6.4.3 Power factor (3)
- 6.4.4 Output power of the motor (3)

6.5 Refer to FIGURE 6.5 below and answer the questions that follow.

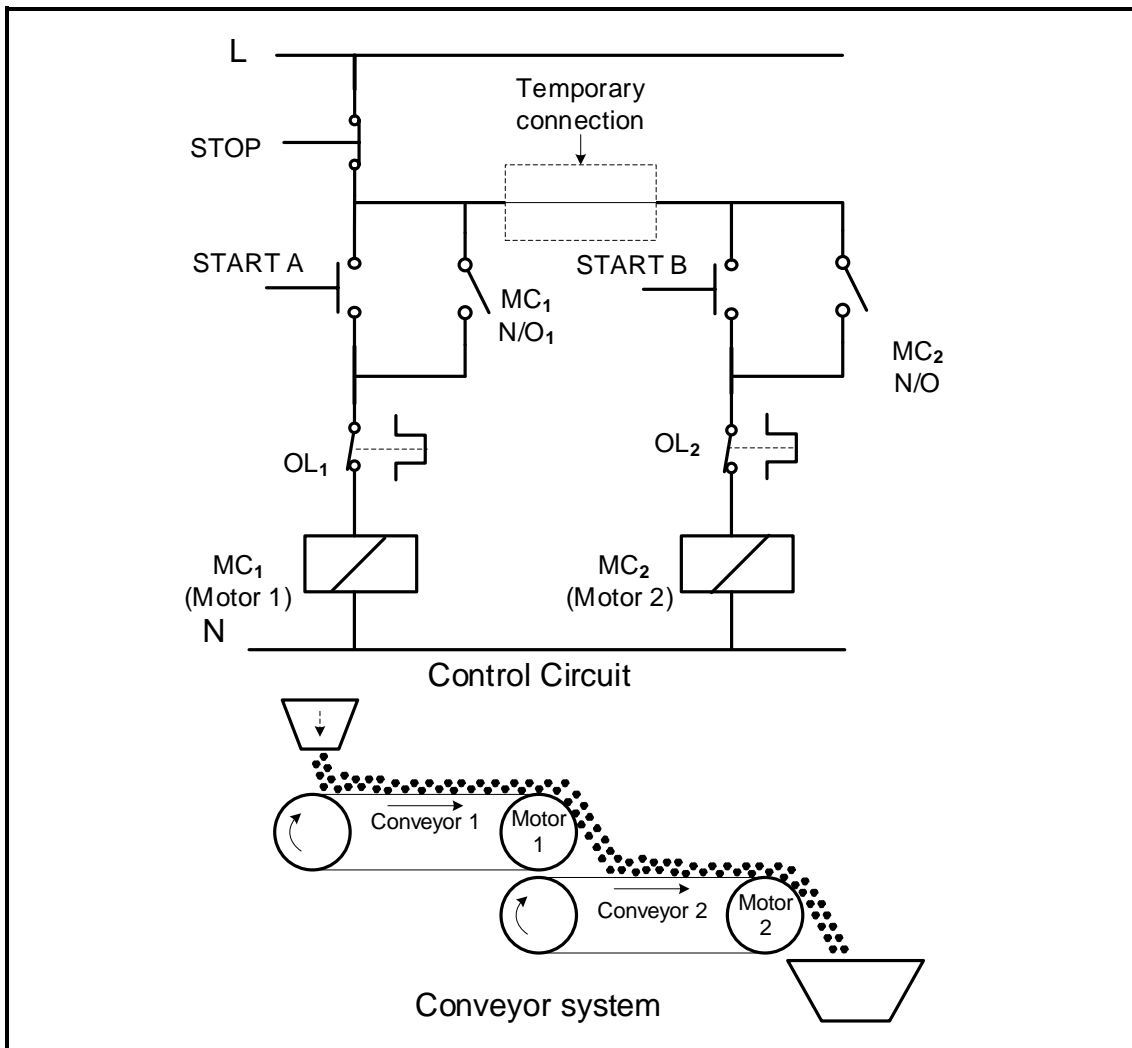

FIGURE 6.5: MOTOR STARTER CONTROL CIRCUIT AND CONVEYOR SYSTEM

6.5.1 Identify the motor starter control circuit in FIGURE 6.5 above. (1)



- 6.5.2 Explain the function of MC₁ with reference to the main (power) circuit. (2)
- 6.5.3 State the advantage of having two overload relays in the circuit. (1)
- 6.5.4 Explain the disadvantage of connecting the overloads as shown in the control circuit in FIGURE 6.5 when MC₁ and MC₂ are controlling the two motors on the conveyor belt system. (3)
- 6.5.5 Currently, MC₂ can be energised either before or after energising MC₁. Explain how the control circuit can be altered to prevent MC₂ from being energised without energising MC₁ first. (2)
- [35]**



QUESTION 7: PROGRAMMABLE LOGIC CONTROLLERS (PLCs)

7.1 State THREE advantages of hard wiring. (3)

7.2 Refer to FIGURE 7.2 below and answer the questions that follow.

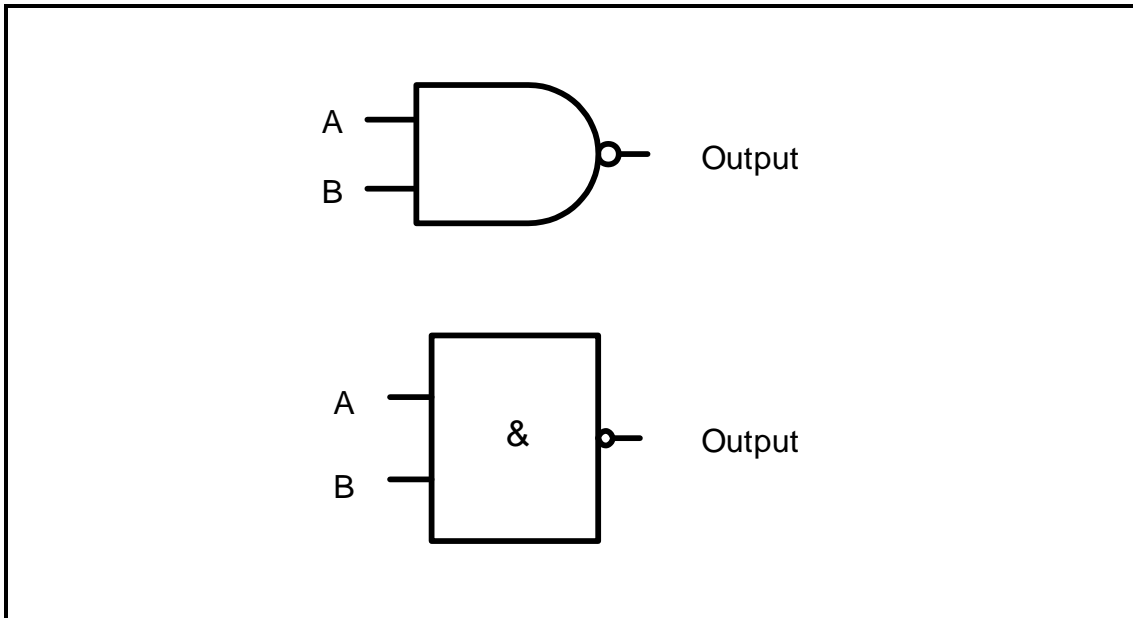

FIGURE 7.2: LOGIC GATE

7.2.1 Draw the ladder logic diagram. (3)

7.2.2 Complete the truth table for the logic gate by writing down only the state of the output for the following TWO input conditions.

A	B	OUTPUT
0	1	(X)
1	1	(Y)

TABLE 7.2.2 (2)

7.3 Refer to analogue and digital inputs on a PLC and answer the questions that follow.

7.3.1 Give THREE examples of analogue input devices. (3)

7.3.2 Explain why an analogue input should be converted to a digital input in a computing device. (4)

7.4 Explain the concept *latching*. (3)



7.5 Refer to FIGURE 7.5 below and answer the questions that follow.

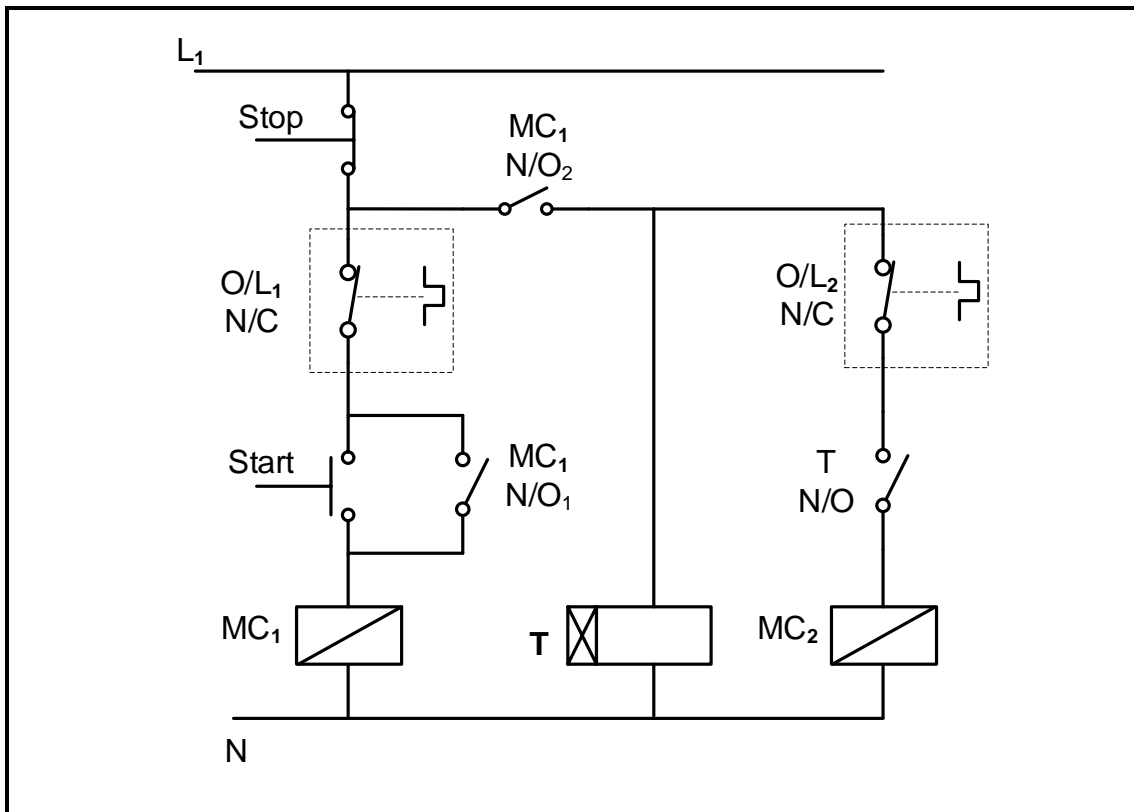

FIGURE 7.5: AUTOMATIC SEQUENCE STARTER

- 7.5.1 Describe the function of T. (2)
- 7.5.2 State TWO conditions that must be met for MC₂ to energise. (2)
- 7.5.3 Differentiate between *ON-delay* and *OFF-delay timers*. (3)
- 7.5.4 In the ANSWER BOOK, redraw the PLC ladder logic diagram in FIGURE 7.5.4 below and complete it so as to execute the same function as the circuit in FIGURE 7.5. above. (9)

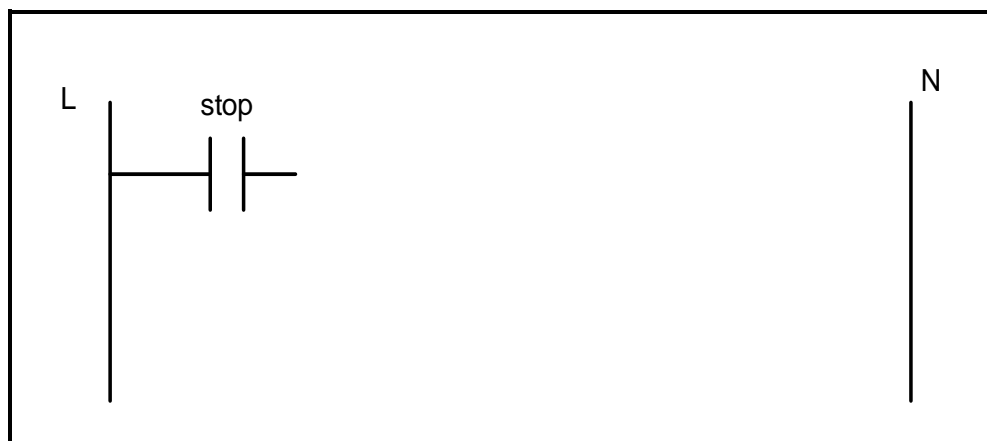

FIGURE 7.5.4



7.6 Refer to a variable speed drive as a programmable motor controller. Describe the basic principle of operation of a variable speed drive when it controls the speed of an AC induction motor. (3)

7.7 FIGURE 7.7 below shows the characteristic curve of speed versus torque when a VSD is used to control the speed of a three-phase induction motor. Study the characteristic curve and describe the start-up and run profile of an induction motor.

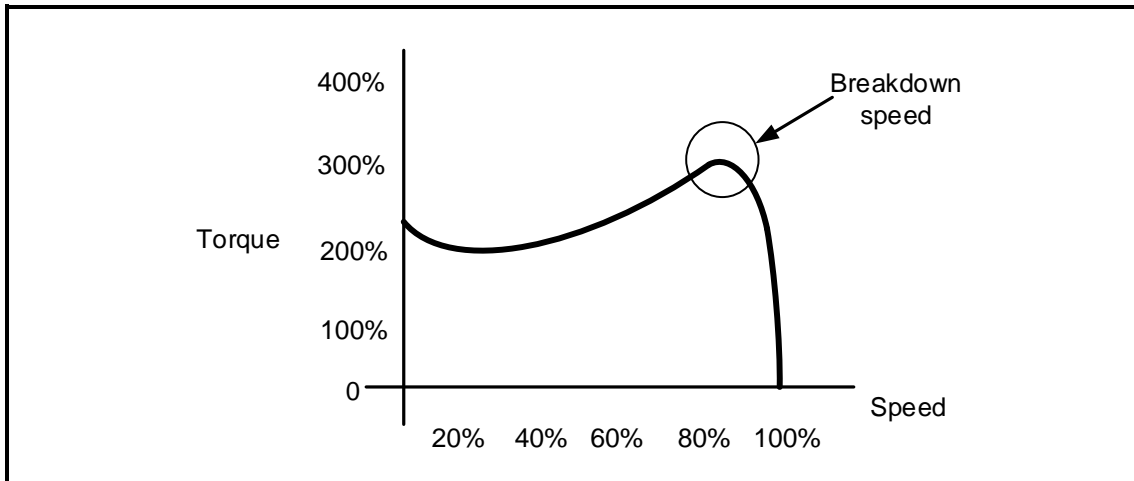

FIGURE 7.7: TORQUE VERSUS SPEED CURVE

(3)
[40]

TOTAL: 200



FORMULA SHEET	
RLC CIRCUITS	THREE-PHASE AC GENERATION
$P = V \times I \times \cos \theta$ $X_L = 2\pi fL$ $X_C = \frac{1}{2\pi fC}$ $f_r = \frac{1}{2\pi\sqrt{LC}} \quad \text{OR} \quad f_r = \frac{f_1 + f_2}{2}$ $BW = \frac{f_r}{Q} \quad \text{OR} \quad BW = f_2 - f_1$ <p>SERIES</p> $V_R = IR$ $V_L = IX_L$ $V_C = IX_C$ $I_T = \frac{V_T}{Z} \quad \text{OR} \quad I_T = I_R = I_C = I_L$ $Z = \sqrt{R^2 + (X_L - X_C)^2}$ $V_T = \sqrt{V_R^2 + (V_L - V_C)^2} \quad \text{OR} \quad V_T = IZ$ $\cos \theta = \frac{R}{Z} \quad \text{OR} \quad \cos \theta = \frac{V_R}{V_T}$ $Q = \frac{X_L}{R} = \frac{X_C}{R} = \frac{V_L}{V_T} = \frac{V_C}{V_T} = \frac{1}{R} \sqrt{\frac{L}{C}}$ <p>PARALLEL</p> $V_T = V_R = V_C = V_L$ $I_R = \frac{V_T}{R}$ $I_C = \frac{V_T}{X_C}$ $I_L = \frac{V_T}{X_L}$ $I_T = \sqrt{I_R^2 + (I_L - I_C)^2}$ $Z = \frac{V_T}{I_T}$ $\cos \theta = \frac{I_R}{I_T}$ $Q = \frac{R}{X_L} = \frac{R}{X_C}$	<p>STAR</p> $V_L = \sqrt{3} V_{PH}$ $V_{PH} = I_{PH} \times Z_{PH}$ $I_L = I_{PH}$ <p>DELTA</p> $V_L = V_{PH}$ $V_{PH} = I_{PH} \times Z_{PH}$ $I_L = \sqrt{3} I_{PH}$ <p>POWER</p> $S(P_{app}) = \sqrt{3} \times V_L \times I_L$ $Q(P_r) = \sqrt{3} \times V_L \times I_L \times \sin \theta$ $P = \sqrt{3} \times V_L \times I_L \times \cos \theta$ $\cos \theta = \frac{P}{S}$ <p>EFFICIENCY</p> $\eta = \frac{P_{OUT}}{P_{IN}} \times 100$ <p>TWO-WATTMETER METHOD</p> $P_T = P_1 + P_2$ $\tan \theta = \sqrt{3} \left(\frac{P_1 - P_2}{P_1 + P_2} \right)$ <p>THREE-WATTMETER METHOD</p> $P_T = P_1 + P_2 + P_3$



THREE-PHASE TRANSFORMERS	THREE-PHASE MOTORS AND STARTERS
<p>STAR $V_L = \sqrt{3} V_{PH}$ $I_L = I_{PH}$</p> <p>DELTA $V_L = V_{PH}$ $I_L = \sqrt{3} I_{PH}$</p> <p>POWER $S(P_{app}) = \sqrt{3} \times V_L \times I_L$ $Q(P_r) = \sqrt{3} \times V_L \times I_L \times \sin \theta$ $P = \sqrt{3} \times V_L \times I_L \times \cos \theta$ $\cos \theta = \frac{P}{S}$ $\frac{V_{PH(1)}}{V_{PH(2)}} = \frac{N_1}{N_2} = \frac{I_{PH(2)}}{I_{PH(1)}}$ Turns ratio: $TR = \frac{N_1}{N_2}$ $\eta = \frac{P_{OUT}}{P_{OUT} + \text{losses}} \times 100$</p>	<p>STAR $V_L = \sqrt{3} V_{PH}$ $I_L = I_{PH}$</p> <p>DELTA $V_L = V_{PH}$ $I_L = \sqrt{3} I_{PH}$</p> <p>POWER $S(P_{app}) = \sqrt{3} \times V_L \times I_L$ $Q(P_r) = \sqrt{3} \times V_L \times I_L \times \sin \theta$ $P = \sqrt{3} \times V_L \times I_L \times \cos \theta$ $P = \sqrt{3} \times V_L \times I_L \times \cos \theta \times \eta$ $\cos \theta = \frac{P}{S}$</p> <p>EFFICIENCY $\eta = \frac{P_{IN} - \text{losses}}{P_{IN}} \times 100$ $\eta = \frac{P_{OUT}}{P_{IN}} \times 100$</p> <p>SPEED $n_s = \frac{60 \times f}{p}$ Per Unit Slip = $\frac{n_s - n_r}{n_s}$ $\% \text{ Slip} = \frac{n_s - n_r}{n_s} \times 100$ $n_r = n_s (1 - \% \text{ slip})$ Slip = $n_s - n_r$</p>

