



basic education

Department:
Basic Education
REPUBLIC OF SOUTH AFRICA

SENIOR CERTIFICATE EXAMINATIONS/ NATIONAL SENIOR CERTIFICATE EXAMINATIONS

PHYSICAL SCIENCES: PHYSICS (P1)

2022

MARKS: 150

TIME: 3 hours



This question paper consists of 16 pages and 3 data sheets.

INSTRUCTIONS AND INFORMATION

1. Write your centre number and examination number in the appropriate spaces in the ANSWER BOOK.
2. This question paper consists of TEN questions. Answer ALL the questions in the ANSWER BOOK.
3. Start EACH question on a NEW page in the ANSWER BOOK.
4. Number the answers correctly according to the numbering system used in this question paper.
5. Leave ONE line between two subquestions, e.g. between QUESTION 2.1 and QUESTION 2.2.
6. You may use a non-programmable calculator.
7. You may use appropriate mathematical instruments.
8. Show ALL formulae and substitutions in ALL calculations.
9. Round off your FINAL numerical answers to a minimum of TWO decimal places.
10. Give brief motivations, discussions, etc. where required.
11. You are advised to use the attached DATA SHEETS.
12. Write neatly and legibly.



QUESTION 1: MULTIPLE-CHOICE QUESTIONS

Various options are provided as possible answers to the following questions. Each question has only ONE correct answer. Choose the answer and write only the letter (A–D) next to the question numbers (1.1 to 1.10) in the ANSWER BOOK, e.g. 1.11 E.

1.1 A bucket is at rest on a table.

Which ONE of the following is the reaction force to the weight of the bucket, as described by Newton's Third Law?

A Force of the table on Earth

B Force of the bucket on Earth

C Force of the bucket on the table

D Force of the table on the bucket

(2)

1.2 A ball is dropped from a small height above the ground.

Ignore air resistance.

The following pairs show physical quantities associated with the ball while it is falling to the ground.

In which ONE of these pairs will BOTH quantities change while the ball is falling?

A Mechanical energy and weight

B Kinetic energy and momentum

C Gravitational acceleration and kinetic energy

D Gravitational potential energy and gravitational force

(2)



1.3 A ball is dropped from height h and strikes the floor with momentum \mathbf{p} .

Ignore air resistance.

The ball is NOW dropped from height $2h$.

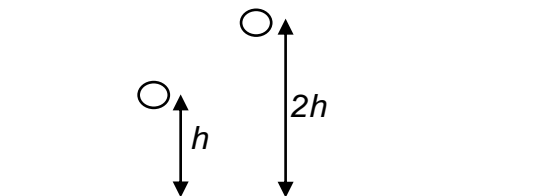

Which ONE of the following represents the momentum with which the ball NOW strikes the floor?

A \mathbf{p}

B $\sqrt{2} \mathbf{p}$

C $2\sqrt{\mathbf{p}}$

D $2\mathbf{p}$

(2)

1.4 Object X exerts a gravitational force \mathbf{F} on object Y when the distance between the centres of the objects is r .

The distance r is now DOUBLED.

Which ONE of the following represents the gravitational force that X now exerts on Y?

A $\frac{1}{4} \mathbf{F}$

B $\frac{1}{2} \mathbf{F}$

C $2\mathbf{F}$

D $4\mathbf{F}$

(2)



- 1.5 A force \mathbf{F} moves an object P from point X to point Y along two different paths, 1 and 2, as shown below.

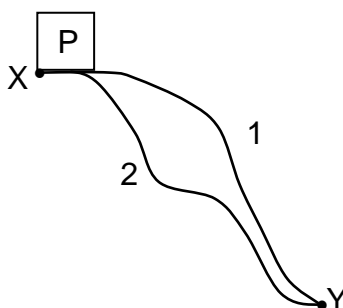

The work done by \mathbf{F} in moving the object is the same for both paths. Which ONE of the following can be used to describe force \mathbf{F} ?

- A Normal force
- B Tension force
- C Frictional force
- D Gravitational force (2)

- 1.6 Which ONE of the following can be explained by the Doppler effect?

- A A stethoscope is used to listen to a person's heartbeat.
- B An echo is heard when sound waves are reflected off a cliff.
- C The spectrum of light from an approaching star is shifted towards shorter wavelengths.
- D Sound intensity decreases when the sound source moves away from a stationary listener. (2)

- 1.7 Two oppositely charged point charges move towards each other.

Which ONE of the following is CORRECT?

The point charges move at ...

- A constant velocity.
- B decreasing velocity.
- C constant acceleration.
- D increasing acceleration. (2)



1.8 Which ONE of the following phrases describes the emf of a battery?

- A Energy supplied per unit time
- B Charge transferred per unit time
- C Current supplied per unit charge
- D Maximum energy supplied per unit charge (2)

1.9 The graph below represents the output voltage versus time for an AC generator.

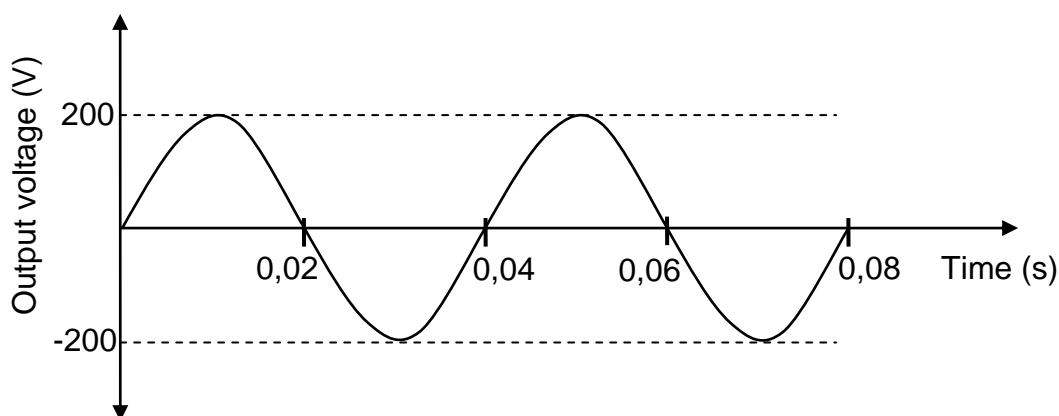

The speed of rotation of the generator's coil is now DOUBLED.

Which ONE of the combinations below shows the CORRECT new peak output voltage and the time for ONE rotation?

	PEAK OUTPUT VOLTAGE (V)	TIME FOR ONE ROTATION (S)
A	400	0,02
B	200	0,02
C	200	0,04
D	100	0,04

(2)

1.10 A photon of light of energy $2X$ joules is shone onto a metal surface with work function X joules.

Which ONE of the following represents the maximum kinetic energy (in joules) of the electron ejected from the metal by this photon?

- A Zero
- B $\frac{1}{2}X$
- C X
- D $2X$

(2)

[20]



QUESTION 2 (Start on a new page.)

A man faces difficulty while swimming in a dam. During the rescue operation, an inflated tube attached to a helicopter by a rope is dropped from the helicopter.

The man, of mass 70 kg, holds onto the inflated tube of mass 4 kg, while the helicopter is flying horizontally at a **CONSTANT** speed. An average frictional force of 300 N is exerted on the man-tube combination while they are dragged horizontally along the surface of the water by the helicopter. The rope makes an angle of 50° with the surface of the water, as shown in the diagram below.

Assume that the rope is inextensible and massless, and the water of the dam does not flow.

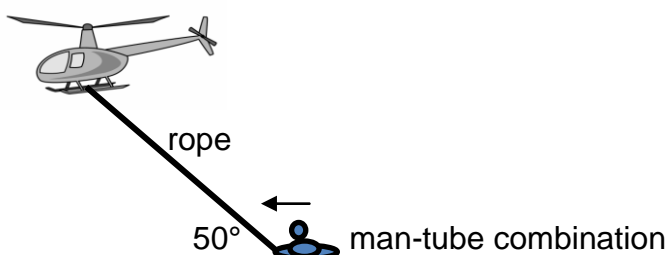

- 2.1 State Newton's First Law of Motion in words. (2)
- 2.2 Draw a free-body diagram of the man-tube combination while they are being dragged. (4)
- 2.3 Calculate the tension in the rope. (4)
- 2.4 How will the answer to QUESTION 2.3 change if the helicopter **ACCELERATES** while dragging the man? The frictional force and the angle between the rope and the surface of the water remain the same.

Choose from **INCREASES**, **DECREASES** or **NO CHANGE**. Give a reason for the answer. (2)

In another rescue operation, the inflated tube of mass 4 kg is dropped from the stationary helicopter and it strikes the water at a speed of $16 \text{ m}\cdot\text{s}^{-1}$. The tube sinks vertically downwards into the water to a depth of 0,8 m and then rises to the surface. The rope hangs loosely.

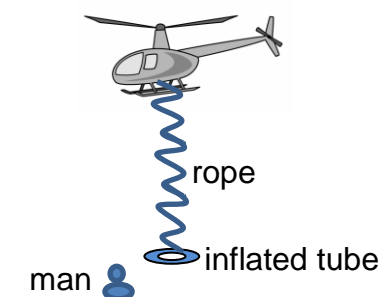

- 2.5 Calculate the magnitude of the average upward force exerted on the inflated tube while it is sinking. Assume that the average upward force is constant for the motion. (5)

[17]



QUESTION 3 (Start on a new page.)

A small disc, **C**, is thrown vertically upwards at a speed of $15 \text{ m}\cdot\text{s}^{-1}$ from the edge of the roof of a building of height 30 m. AFTER 0,5 s, a small ball **B** is shot vertically upwards from the foot of the building at a speed of $40 \text{ m}\cdot\text{s}^{-1}$ in order to hit disc **C**.

Ignore the effects of air resistance.

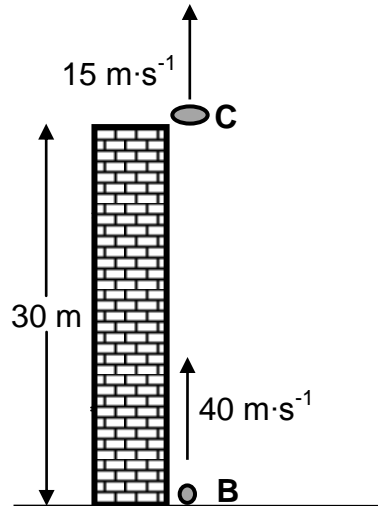

- 3.1 Explain the term *projectile*. (2)
- 3.2 Calculate the:
- 3.2.1 Time taken by disc **C** to reach its maximum height (3)
- 3.2.2 Maximum height above the ground reached by disc **C** (4)
- 3.3 Calculate the time from the moment that disc **C** was thrown upwards until the time ball **B** hits the disc. (6)
- 3.4 On the same set of axes, sketch graphs of velocity versus time for disk **C** and ball **B** from the moment that disc **C** was thrown upwards until ball **B** hits disc **C**.

Label the graph for ball **B** as B and the graph for disc **C** as C.

Clearly indicate the following on the graphs:

- The initial velocities of ball **B** and disc **C**
- The time at which ball **B** was shot upward
- The time at which disc **C** reaches its maximum height
- The time at which ball **B** hits disc **C**

(5)
[20]



QUESTION 4 (Start on a new page.)

4.1 What is meant by an *isolated system* in physics? (2)

During an experiment, a rocket of unknown mass is mounted on a toy cart of mass 20 kg. The cart-rocket combination moves at a constant speed of $2,5 \text{ m}\cdot\text{s}^{-1}$ along a horizontal floor.

At a certain instant, the rocket is fired horizontally in the direction of motion at a speed of $30 \text{ m}\cdot\text{s}^{-1}$. As a result, the cart slows down to a speed of $0,6 \text{ m}\cdot\text{s}^{-1}$, as shown in the diagram below.

Ignore frictional effects.

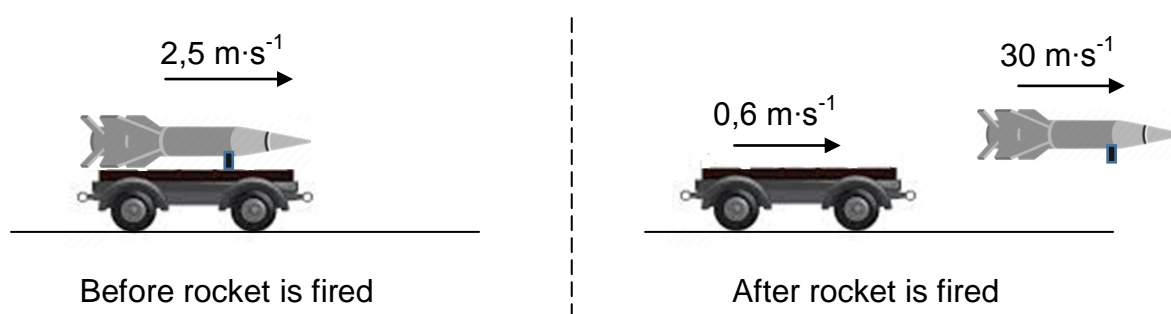

4.2 Use relevant physics principles to explain why the firing of the rocket will slow down the cart. (2)

4.3 Calculate the mass of the rocket at the instant the rocket was fired from the toy cart. (5)

[9]



QUESTION 5 (Start on a new page.)

Arrestor beds are used to help moving trucks to come to a stop when their brakes fail.

The driver of a 30 000 kg truck driving down a steep road drives onto an ASCENDING arrestor bed inclined at 28° to the horizontal, as shown in the diagram below.

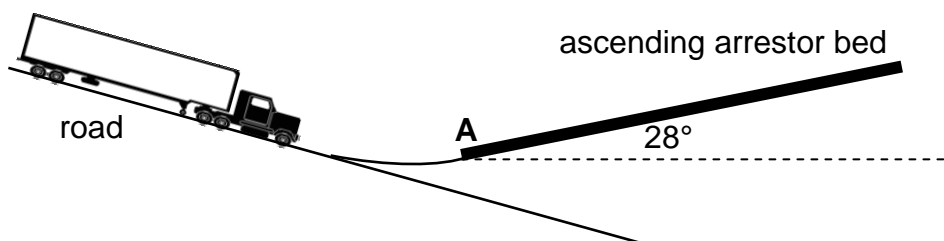

5.1 State the work-energy theorem in words. (2)

The truck with failed brakes passes point **A** at the beginning of the arrestor bed at a speed of $33 \text{ m}\cdot\text{s}^{-1}$. The average frictional force on the truck is 31 000 N while the truck moves up the arrestor bed.

Ignore the rotational effects of the wheels.

5.2 Give a reason why the net work done on the truck, while moving on the arrestor bed, is negative. (1)

5.3 Use ENERGY PRINCIPLES to calculate the minimum length of the arrestor bed needed to bring the truck to a stop. (5)

The diagram below shows the same truck entering a DESCENDING arrestor bed inclined at 28° to the horizontal. The initial speed of the truck and the average frictional force on the truck are $33 \text{ m}\cdot\text{s}^{-1}$ and 31 000 N respectively.

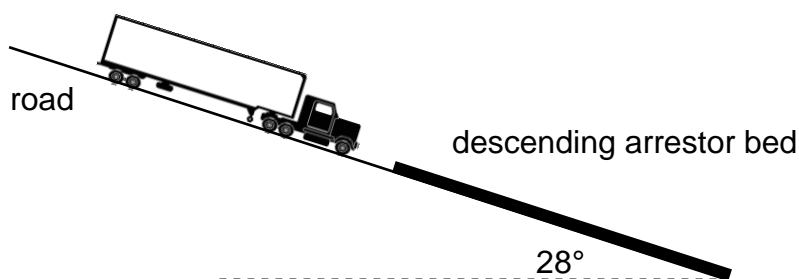

5.4 Which arrestor bed, ASCENDING or DESCENDING, will be able to stop the truck in a shorter distance?

Explain the answer in terms of the forces acting on the truck.

(3)
[11]



QUESTION 6 (Start on a new page.)

A car moves at a constant speed of $10 \text{ m}\cdot\text{s}^{-1}$ TOWARDS a stationary sound source. The sound source emits sound waves of frequency 880 Hz .

A sound detector **A** is attached to the car and another sound detector **B** is attached to the sound source. Detector **B** detects the sound waves reflected from the car.

The speed of sound in air is $340 \text{ m}\cdot\text{s}^{-1}$.



- 6.1 State the Doppler effect in words. (2)
- 6.2 Calculate the wavelength of the sound waves emitted by the source. (3)
- 6.3 Calculate the frequency of the sound waves detected by detector **A**. (4)

The sketch graph below shows the frequency recorded by detector **A**.

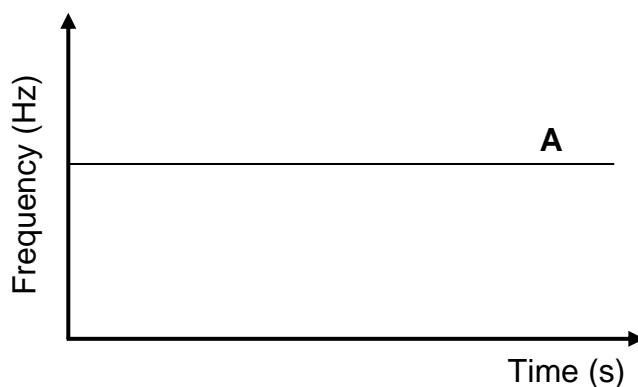

- 6.4 Redraw the graph above for detector **A** in your ANSWER BOOK. On the same set of axes, sketch the graph of the frequency recorded by detector **B**. Label this graph as B. (2)

[11]



QUESTION 7 (Start on a new page.)

- 7.1 Two small, identical spheres, **P** and **T**, are placed a distance of 0,1 m apart, as shown in the diagram below. **P** carries a charge of $+3 \times 10^{-6}$ C and **T** carries a charge of -3×10^{-6} C.

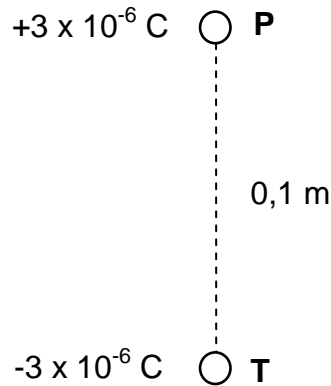

- 7.1.1 State Coulomb's law in words. (2)
- 7.1.2 Draw the resultant electric field pattern due to the charges on **P** and **T**. (3)

A third charged sphere **S** of unknown charge Q_s is placed a distance of 0,15 m from sphere **T** such that the three charged spheres are at the vertices of a right-angled triangle.

The net electrostatic force on sphere **T** due to the other two charged spheres has a magnitude of 10 N, as shown in the diagram below.

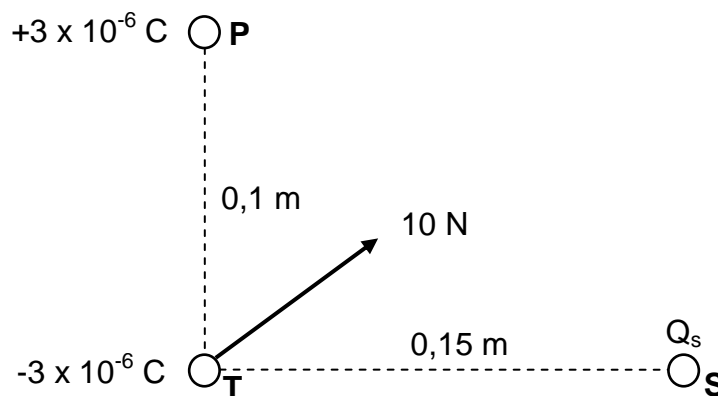

- 7.1.3 Is charge Q_s POSITIVE or NEGATIVE? (1)
- 7.1.4 Calculate the number of electrons added to or removed from sphere **S** to give it a charge of Q_s . (6)



- 7.2 **P** is a variable point in the electric field of charged sphere **A** and **r** is the distance between point **P** and the centre of sphere **A**. See the diagram below.

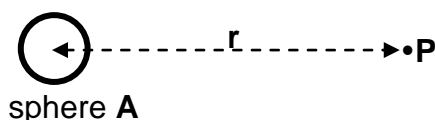

A learner determines the magnitude of the electric field (**E**) at point **P** for different values of **r**.

Sphere **A** is then replaced by another sphere, **B**, of a different charge. Another set of results are obtained.

The graphs below are obtained from the results for sphere **A** and sphere **B**. E_A is the magnitude of the electric field at a distance of 0,04 m from the centre of charged sphere **A**.

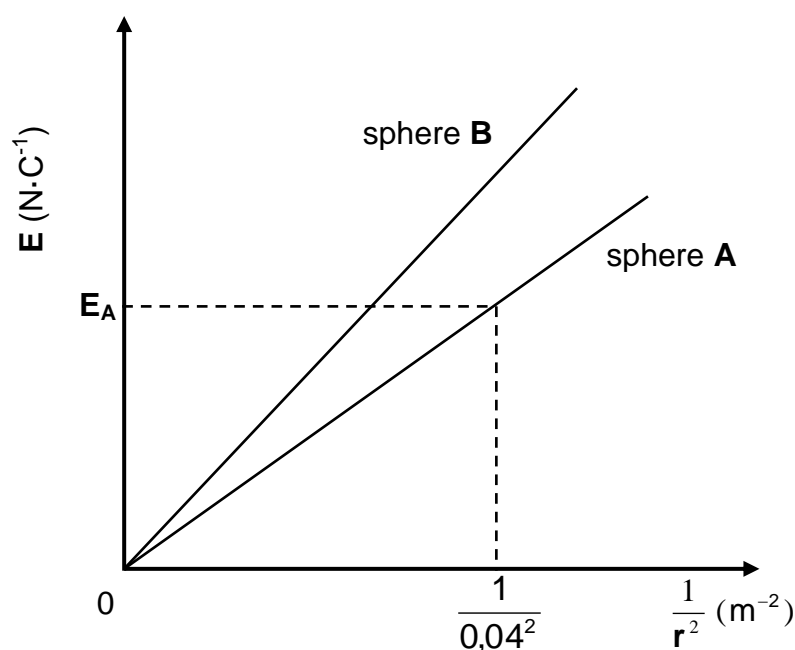

Use the graphs to answer the following questions.

- 7.2.1 State the proportionality between the magnitude of electric field **E** at a point and $\frac{1}{r^2}$. (1)
- 7.2.2 Calculate E_A if the numerical value of the gradient of the graph for sphere **A** is 680. (4)
- 7.2.3 How does the magnitude of the charge on sphere **B** compare to the magnitude of the charge on sphere **A**?

Choose from GREATER THAN, SMALLER THAN or EQUAL TO.
Give a reason for the answer.

(3)
[20]



QUESTION 8 (Start on a new page.)

In the circuit below a battery of UNKNOWN emf and an internal resistance of $0,5 \Omega$ is connected to two resistors of 4Ω and 8Ω each, and a resistor **R** of unknown resistance.

Ignore the resistance of the connecting wires.

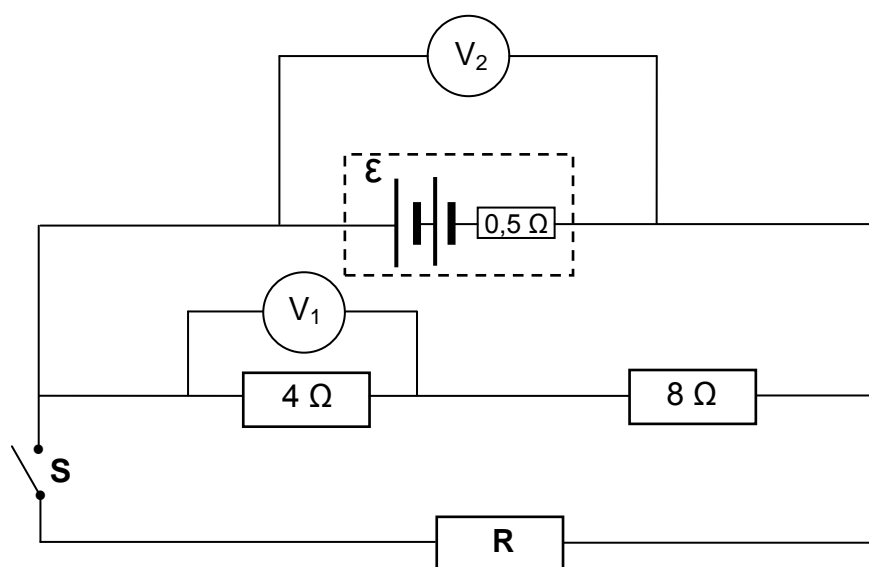

- 8.1 The three external resistors are ohmic conductors.
Explain the meaning of the term *ohmic conductor*. (2)
- 8.2 When switch **S** is OPEN, voltmeter V_1 reads 3,2 V.
Calculate the:
- 8.2.1 Current through the battery (3)
- 8.2.2 Emf of the battery (4)
- 8.3 When switch **S** is CLOSED, voltmeter V_2 reads 8,8 V.
- 8.3.1 Calculate the resistance of resistor **R**. (5)
- 8.3.2 The battery becomes heated when voltmeter V_2 is replaced by a connecting wire. Explain this observation. (3)

[17]

QUESTION 9 (Start on a new page.)

9.1 The simplified sketch of an electric motor is shown below.

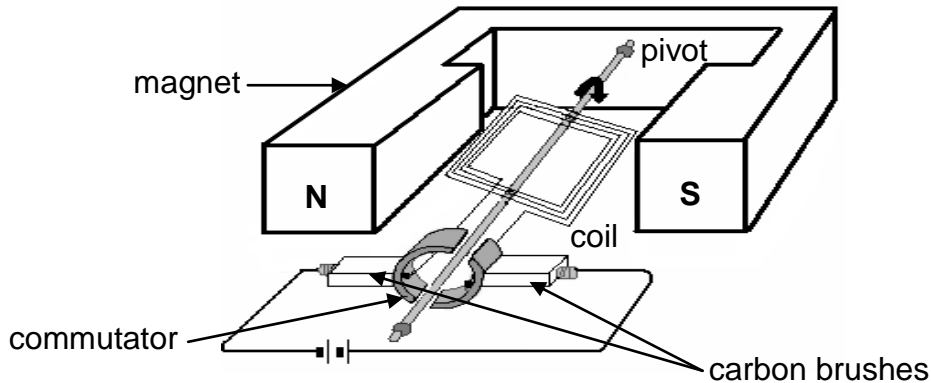

- 9.1.1 Write down the energy conversion that takes place in this motor. (1)
- 9.1.2 Is the motor above an AC motor or a DC motor? (1)
- 9.1.3 What is the function of the commutator in this motor? (1)

9.2 A resistor **Y** is rated 220 V, 100 W and is connected to a 220 V AC source, as shown in the circuit below.

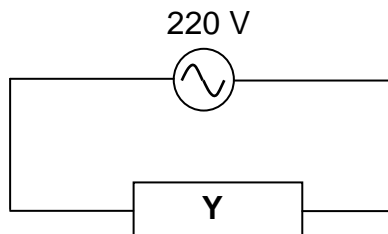

- 9.2.1 Calculate the resistance of resistor **Y**. (3)

Another resistor **Z** with a rating 220 V, X W, is now connected in series to resistor **Y** and to the same AC source. See the diagram below.

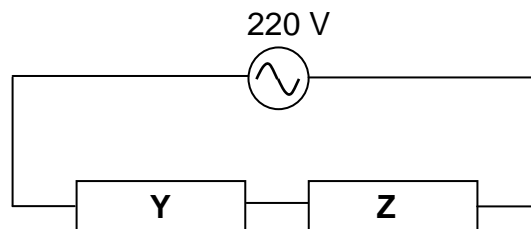

The power dissipated by resistor **Y** changes to 80 W, while its resistance remains constant.

- 9.2.2 Calculate the power rating X of resistor **Z**, assuming that resistor **Z** has constant resistance. (6)

[12]



QUESTION 10 (Start on a new page.)

- 10.1 The apparatus illustrated in the simplified diagram below is used to demonstrate the photoelectric effect.

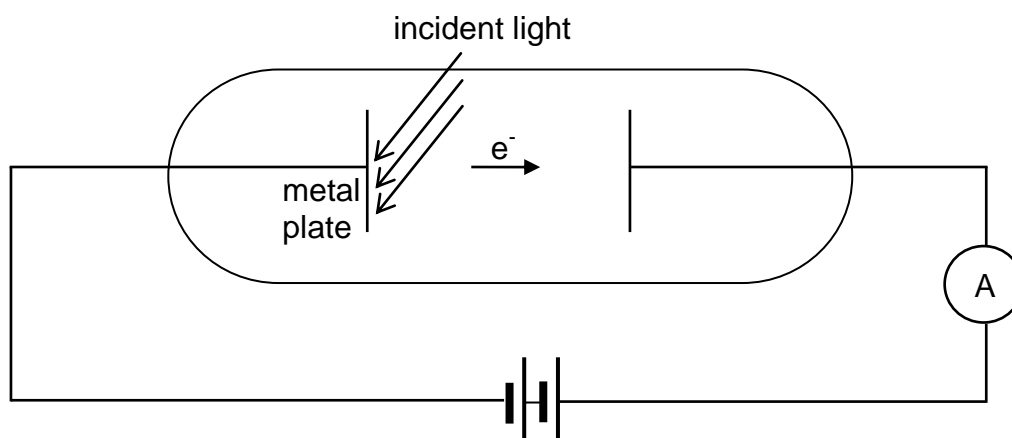

- 10.1.1 Define the term *photoelectric effect*. (2)

Incident light of frequency $1,2 \times 10^{15}$ Hz is shone onto the metal plate and electrons are emitted.

Calculate the:

- 10.1.2 Number of photoelectrons emitted in one second if the total energy transferred by the light to the metal plate per second is $1,75 \times 10^{-9}$ J (4)

- 10.1.3 Maximum speed of a photoelectron if the threshold frequency of the metal plate is $9,09 \times 10^{14}$ Hz (5)

- 10.2 Briefly explain how an emission spectrum is formed in terms of energy transitions. (2)
[13]

TOTAL: 150



**DATA FOR PHYSICAL SCIENCES GRADE 12
PAPER 1 (PHYSICS)**

**GEGEWENS VIR FISIESTE WETENSKAPPE GRAAD 12
VRAESTEL 1 (FISIKA)**

TABLE 1: PHYSICAL CONSTANTS/TABEL 1: FISIESTE KONSTANTES

NAME/NAAM	SYMBOL/SIMBOOL	VALUE/WAARDE
Acceleration due to gravity <i>Swaartekragversnelling</i>	g	9,8 m·s ⁻²
Universal gravitational constant <i>Universele gravitasiekonstant</i>	G	6,67 x 10 ⁻¹¹ N·m ² ·kg ⁻²
Radius of the Earth <i>Radius van die Aarde</i>	R _E	6,38 x 10 ⁶ m
Mass of the Earth <i>Massa van die Aarde</i>	M _E	5,98 x 10 ²⁴ kg
Speed of light in a vacuum <i>Spoed van lig in 'n vakuum</i>	c	3,0 x 10 ⁸ m·s ⁻¹
Planck's constant <i>Planck se konstante</i>	h	6,63 x 10 ⁻³⁴ J·s
Coulomb's constant <i>Coulomb se konstante</i>	k	9,0 x 10 ⁹ N·m ² ·C ⁻²
Charge on electron <i>Lading op elektron</i>	e	-1,6 x 10 ⁻¹⁹ C
Electron mass <i>Elektronmassa</i>	m _e	9,11 x 10 ⁻³¹ kg



TABLE 2: FORMULAE/TABEL 2: FORMULES**MOTION/BEWEGING**

$v_f = v_i + a \Delta t$	$\Delta x = v_i \Delta t + \frac{1}{2} a \Delta t^2$ or/of $\Delta y = v_i \Delta t + \frac{1}{2} a \Delta t^2$
$v_f^2 = v_i^2 + 2a\Delta x$ or/of $v_f^2 = v_i^2 + 2a\Delta y$	$\Delta x = \left(\frac{v_i + v_f}{2} \right) \Delta t$ or/of $\Delta y = \left(\frac{v_i + v_f}{2} \right) \Delta t$

FORCE/KRAG

$F_{\text{net}} = ma$	$p = mv$
$f_s^{\text{max}} = \mu_s N$	$f_k = \mu_k N$
$F_{\text{net}} \Delta t = \Delta p$ $\Delta p = mv_f - mv_i$	$w = mg$
$F = G \frac{m_1 m_2}{d^2}$ or/of $F = G \frac{m_1 m_2}{r^2}$	$g = G \frac{M}{d^2}$ or/of $g = G \frac{M}{r^2}$

WORK, ENERGY AND POWER/ARBEID, ENERGIE EN DRYWING

$W = F \Delta x \cos \theta$	$U = mgh$ or/of $E_p = mgh$
$K = \frac{1}{2} mv^2$ or/of $E_k = \frac{1}{2} mv^2$	$W_{\text{net}} = \Delta K$ or/of $W_{\text{net}} = \Delta E_k$ $\Delta K = K_f - K_i$ or/of $\Delta E_k = E_{kf} - E_{ki}$
$W_{\text{nc}} = \Delta K + \Delta U$ or/of $W_{\text{nc}} = \Delta E_k + \Delta E_p$	$P = \frac{W}{\Delta t}$
$P_{\text{ave}} = F v_{\text{ave}}$ / $P_{\text{gemid}} = F v_{\text{gemid}}$	

WAVES, SOUND AND LIGHT/GOLWE, KLANK EN LIG

$v = f \lambda$	$T = \frac{1}{f}$
$f_L = \frac{v \pm v_L}{v \pm v_s} f_s$ or/of $f_L = \frac{v \pm v_L}{v \pm v_b} f_b$	$E = hf$ or /of $E = \frac{hc}{\lambda}$
$E = W_0 + E_{k(\text{max})}$ or $E = W_0 + K_{\text{max}}$ where $E = hf$ and $W_0 = hf_0$ and $E_{k(\text{max})} = \frac{1}{2} mv_{\text{max}}^2$ / $K_{\text{max}} = \frac{1}{2} mv_{\text{max}}^2$	
$E = W_0 + E_{k(\text{maks})}$ of $E = W_0 + K_{\text{maks}}$ waar $E = hf$ en $W_0 = hf_0$ en $E_{k(\text{maks})} = \frac{1}{2} mv_{\text{maks}}^2$ / $K_{\text{maks}} = \frac{1}{2} mv_{\text{maks}}^2$	



ELECTROSTATICS/ELEKTROSTATIKA

$F = \frac{kQ_1Q_2}{r^2}$	$E = \frac{kQ}{r^2}$
$V = \frac{W}{q}$	$E = \frac{F}{q}$
$n = \frac{Q}{e}$ or/of $n = \frac{Q}{q_e}$	

ELECTRIC CIRCUITS/ELEKTRIESE STROOMBANE

$R = \frac{V}{I}$	emf (ϵ) = I(R + r) emk (ϵ) = I(R + r)
$R_s = R_1 + R_2 + \dots$ $\frac{1}{R_p} = \frac{1}{R_1} + \frac{1}{R_2} + \dots$	$q = I\Delta t$
$W = Vq$ $W = VI\Delta t$ $W = I^2R\Delta t$ $W = \frac{V^2\Delta t}{R}$	$P = \frac{W}{\Delta t}$ $P = VI$ $P = I^2R$ $P = \frac{V^2}{R}$

ALTERNATING CURRENT/WISSELSTROOM

$I_{rms} = \frac{I_{max}}{\sqrt{2}}$ / $I_{wgk} = \frac{I_{maks}}{\sqrt{2}}$	$P_{ave} = V_{rms}I_{rms}$ / $P_{gemiddeld} = V_{wgk}I_{wgk}$
$V_{rms} = \frac{V_{max}}{\sqrt{2}}$ / $V_{wgk} = \frac{V_{maks}}{\sqrt{2}}$	$P_{ave} = I_{rms}^2R$ / $P_{gemiddeld} = I_{wgk}^2R$
	$P_{ave} = \frac{V_{rms}^2}{R}$ / $P_{gemiddeld} = \frac{V_{wgk}^2}{R}$

