



basic education

Department:
Basic Education
REPUBLIC OF SOUTH AFRICA

SENIOR CERTIFICATE EXAMINATIONS/ NATIONAL SENIOR CERTIFICATE EXAMINATIONS

MECHANICAL TECHNOLOGY: AUTOMOTIVE

2022

MARKS: 200

TIME: 3 hours



This question paper consists of 15 pages and a 2-page formula sheet.

INSTRUCTIONS AND INFORMATION

1. Write your centre number and examination number in the spaces provided on the ANSWER BOOK.
2. Read ALL the questions carefully.
3. Answer ALL the questions.
4. Number the answers correctly according to the numbering system used in this question paper.
5. Start EACH question on a NEW page.
6. Show ALL calculations and units. Round off final answers to TWO decimal places.
7. Candidates may use non-programmable scientific calculators and drawing instruments.
8. The value of gravitational acceleration should be taken as 10 m/s^2 .
9. All dimensions are in millimetres, unless stated otherwise in the question.
10. Write neatly and legibly.
11. A formula sheet is attached at the end of the question paper.
12. Use the criteria below to assist you in managing your time.

| QUESTION | CONTENT | MARKS | TIME IN MINUTES |
|--------------|--|------------|-----------------|
| | GENERIC | | |
| 1 | Multiple-choice Questions | 6 | 6 |
| 2 | Safety | 10 | 10 |
| 3 | Materials | 14 | 14 |
| | SPECIFIC | | |
| 4 | Multiple-choice Questions | 14 | 10 |
| 5 | Tools and Equipment | 23 | 20 |
| 6 | Engines | 28 | 25 |
| 7 | Forces | 32 | 25 |
| 8 | Maintenance | 23 | 20 |
| 9 | Systems and Control (Automatic Gearbox) | 18 | 20 |
| 10 | Systems and Control (Axles, Steering Geometry and Electronics) | 32 | 30 |
| TOTAL | | 200 | 180 |



QUESTION 1: MULTIPLE-CHOICE QUESTIONS (GENERIC)

Various options are provided as possible answers to the following questions. Choose the answer and write only the letter (A–D) next to the question numbers (1.1 to 1.6) in the ANSWER BOOK e.g. 1.7 E.

- 1.1 Which ONE of the following safety procedures relates to the operation of a hydraulic press?
- A The platform on which the work piece rests must be rigid and perpendicular to the press cylinder.
 - B Make sure all gas valves in the cylinders are properly adjusted.
 - C Chips can be removed while the machine press is in operation.
 - D Ensure that the maximum air pressure is not exceeded in the cylinders. (1)
- 1.2 Which safety measure is applicable to drilling machines?
- A Leave the key in the chuck when the machine is not operated.
 - B Choose a correctly sharpened drill bit for the type of work you need to do.
 - C There is no need to wear safety goggles.
 - D Leave the machine running while having lunch. (1)
- 1.3 Which ONE of the following types of personal protective equipment (PPE) is required when arc welding a work piece?
- A Hard hat
 - B Welding goggles
 - C Welding helmet
 - D Cotton gloves (1)
- 1.4 Which ONE of the following types of steel is the easiest to cut?
- A High-speed steel
 - B Cast iron
 - C Cast steel
 - D Mild steel (1)
- 1.5 Which method can be used to conduct a sound test?
- A Dropping the work piece on a concrete floor
 - B Drilling into the metal
 - C Using a surface grinder
 - D Welding the metal (1)
- 1.6 Nitriding is done during the ... process.
- A hardening
 - B annealing
 - C case-hardening
 - D normalising (1)

[6]

QUESTION 2: SAFETY (GENERIC)

- 2.1 Why should the rated speed of the grinding wheel never exceed the maximum speed of the grinder? (1)
- 2.2 State TWO safety precautions that should be observed while the vertical band saw is in operation. (2)
- 2.3 Identify the THREE stages in which first aid is applied. (3)
- 2.4 Name the TWO main categories into which the causes of accidents can be divided according to the Occupational Health and Safety Act. (2)
- 2.5 State TWO advantages of the product workshop layout. (2)

[10]**QUESTION 3: MATERIALS (GENERIC)**

- 3.1 Define *tempering* of steel. (2)
- 3.2 Give THREE reasons why the annealing process is conducted on steel. (3)
- 3.3 At what approximate temperature is steel heated during the normalising process? (2)
- 3.4 Identify the type of steel/iron from the spark patterns shown in FIGURES 3.4.1–3.4.3 below.

3.4.1

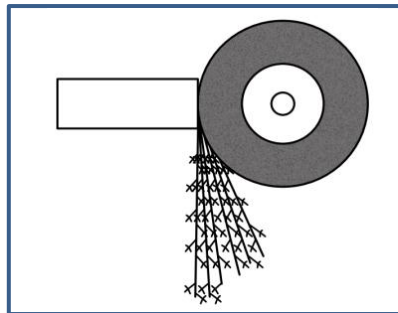
**FIGURE 3.4.1**

(1)

3.4.2

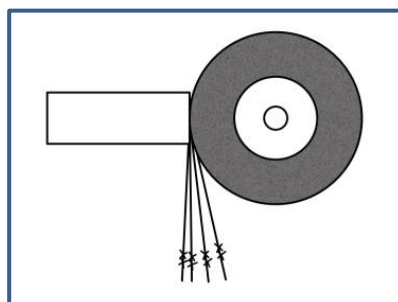
**FIGURE 3.4.2**

(1)



3.4.3

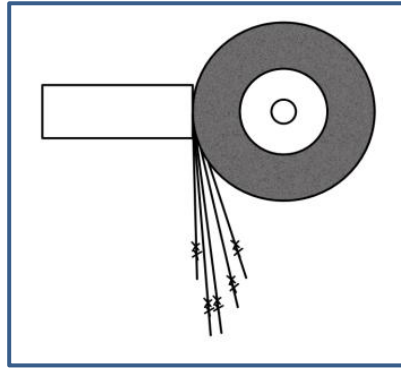

FIGURE 3.4.3

(1)

3.5 FIGURE 3.5 below shows an iron-carbon equilibrium diagram. Label **A** to **D**.

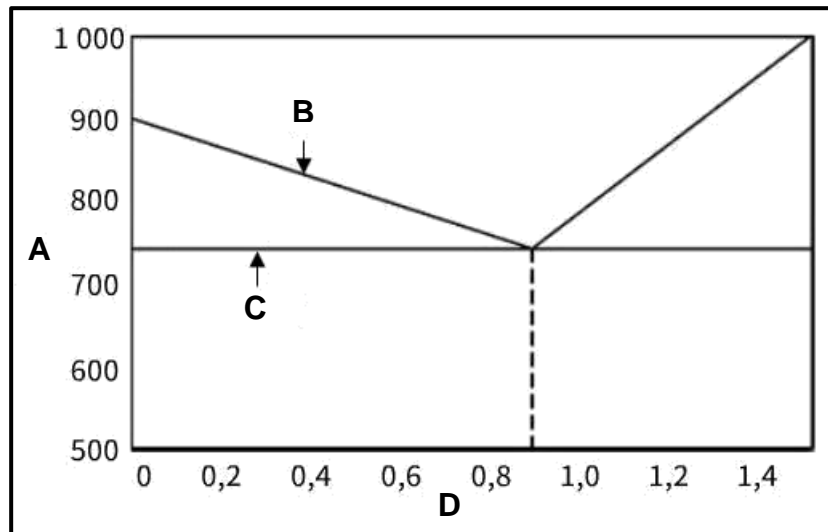

FIGURE 3.5

(4)
[14]



QUESTION 4: MULTIPLE-CHOICE QUESTIONS (SPECIFIC)

Various options are provided as possible answers to the following questions. Choose the answer and write only the letter (A–D) next to the question numbers (4.1 to 4.14) in the ANSWER BOOK e.g. 4.15 E.

4.1 What is the function of the pressure relief valve on the compression tester?

- A Ensures that the tester's maximum pressure is not exceeded
- B Reveals the condition of the engine
- C Relieves pressure in the tester in preparation for the next test
- D Prevents a loss of pressure

(1)

4.2 While performing wheel balancing, the wheel weight hammer is used to ...

- A knock out dents on the wheel rim.
- B cut the wheel weights.
- C cut the tyre treads.
- D stop the wheel from spinning.

(1)

4.3 Which ONE diagram below shows the crank positions of a three-cylinder in-line engine?

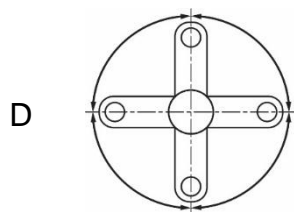
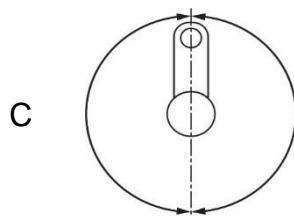
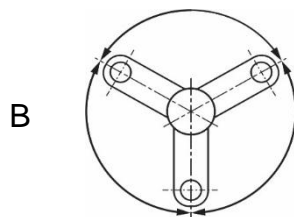
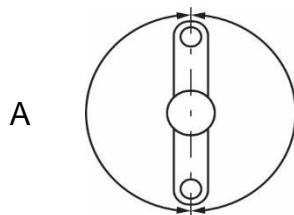

(1)



- 4.4 With reference to a four-stroke four-cylinder engine, which cylinder is firing if the valves of cylinder 1 are rocking? (1)
- A Cylinder 1
 - B Cylinder 2
 - C Cylinder 3
 - D Cylinder 4
- 4.5 The swept volume is the measuring of the ... (1)
- A volume between the TDC and BDC of the cylinder.
 - B valve clearance volume.
 - C total capacity of the engine.
 - D combustion chamber volume.
- 4.6 Which ONE of the following volumes represents a capacity of 1 litre? (1)
- A 1 000 mm³
 - B 1 cm³
 - C 1 000 cm³
 - D 1 m³
- 4.7 The brake power is the power available ... (1)
- A in the engine cylinder.
 - B at the flywheel.
 - C at the crank pin.
 - D at the camshaft.
- 4.8 Which ONE of the following is a possible cause of low oil pressure in an engine? (1)
- A Blocked oil passages
 - B Oil viscosity is too high
 - C Worn oil pump
 - D Pressure relief valve not opening
- 4.9 During a cooling system pressure test, pressure is applied by ... (1)
- A compressed air from a compressor.
 - B the water pump.
 - C a hand-operated pump.
 - D a hydraulic pump.
- 4.10 Which ONE of the following is part of the automatic transmission gearbox? (1)
- A Impeller
 - B Brake bands
 - C Turbine
 - D Stator



4.11 Drive is transmitted from the ... to the output shaft of a double epicyclic gear system.

- A annulus
- B sun gear
- C planet gear carrier
- D clutches

(1)

4.12 Which component in an alternator is a rotating electromagnet?

- A Rotor
- B Stator
- C Rectifier
- D Voltage regulator

(1)

4.13 Identify wheel alignment angle **W** in FIGURE 4.13 below.

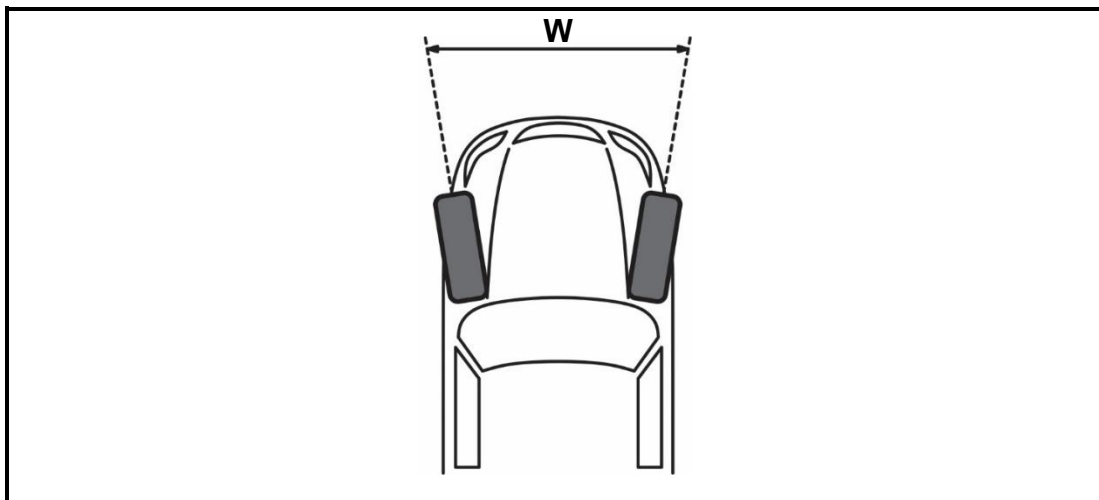

FIGURE 4.13

- A Camber
- B Toe-out
- C Castor
- D King pin inclination

(1)

4.14 Which ONE of the following is an air induction sensor?

- A Knock sensor
- B Crankshaft position sensor
- C Spark plug
- D MAP sensor

(1)

[14]

QUESTION 5: TOOLS AND EQUIPMENT (SPECIFIC)

- 5.1 Describe how a wet compression test is done on an internal combustion engine. (3)
- 5.2 Explain the functions of the following tests done on an internal combustion engine:
- 5.2.1 Compression test (2)
- 5.2.2 Cylinder leakage test (2)
- 5.3 State FOUR precautions to be taken when using a gas analyser. (4)
- 5.4 Explain how the optical alignment gauges are used to measure wheel alignment after they have been calibrated. (5)
- 5.5 Describe how you would conduct a computerised diagnostic test on a vehicle using the on-board diagnostics (OBD-II) scanner. (5)
- 5.6 Name TWO methods used to balance the wheels of a motor vehicle. (2)
- [23]**



QUESTION 6: ENGINES (SPECIFIC)

- 6.1 Name FOUR components of a motor vehicle that are driven by the crankshaft. (4)
- 6.2 Explain the following terms with regard to an internal combustion engine:
- 6.2.1 Rotating mass (2)
- 6.2.2 Reciprocating mass (2)
- 6.3 State TWO advantages of a six-cylinder V-engine over a six-cylinder straight engine. (2)
- 6.4 FIGURE 6.4 below shows a turbocharger. Answer the questions that follow.

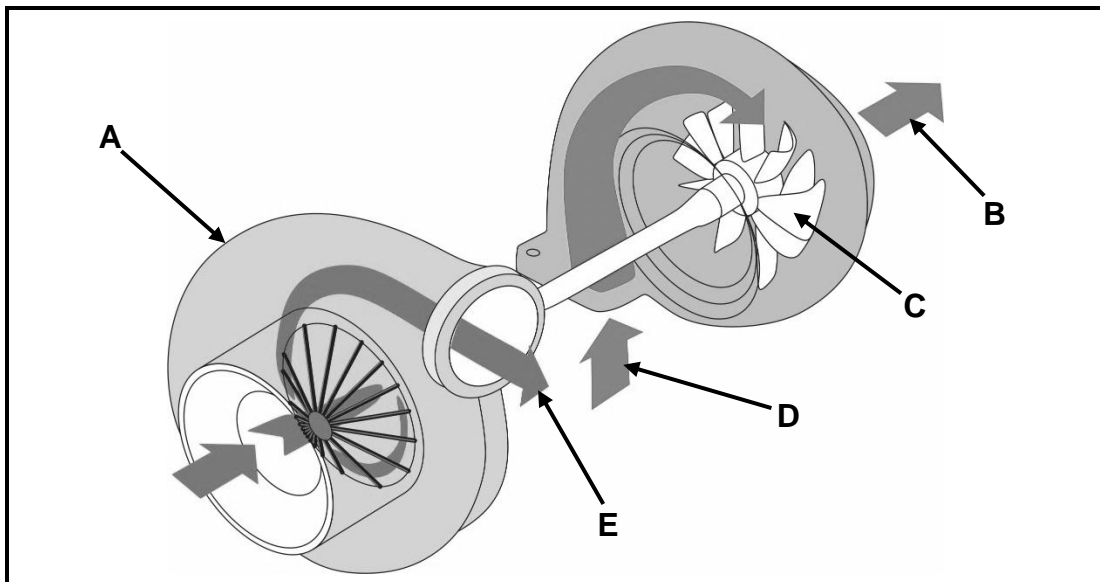
**FIGURE 6.4**

- 6.4.1 Label parts **A–E**. (5)
- 6.4.2 Explain how the vanes in a variable geometry turbocharger help to speed up the rotation of the turbocharger at low speed. (4)
- 6.5 Name FOUR different types of superchargers. (4)
- 6.6 State THREE disadvantages of superchargers compared to turbochargers. (3)
- 6.7 What is the difference between *twin-turbocharging* and *twin-charging*? (2)

[28]

QUESTION 7: FORCES (SPECIFIC)

7.1 Define the following terms with regard to an internal combustion engine:

7.1.1 Work done (2)

7.1.2 Clearance volume (2)

7.2 FIGURE 7.2 below shows a diagram of a four-stroke, spark-ignition (S.I.) engine. Answer the questions that follow.

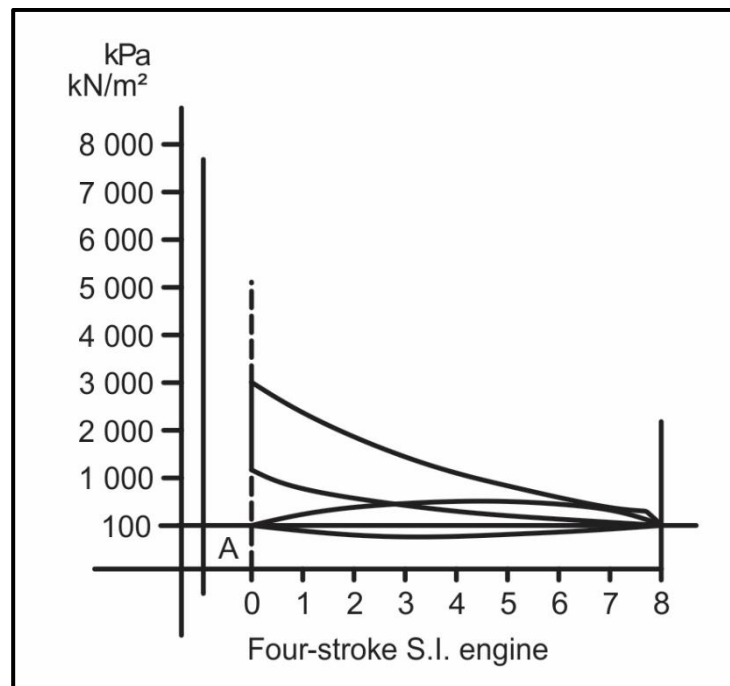

FIGURE 7.2

7.2.1 Identify the diagram in FIGURE 7.2. (1)

7.2.2 What is the unit of the mean effective pressure? (1)

7.3 The bore of an engine is 7 cm and the stroke is 65 mm. The compression ratio is 9 : 1.

Determine the following by means of calculations:

7.3.1 The swept volume in cm^3 (3)

7.3.2 The original clearance volume in cm^3 (3)

7.3.3 The new stroke length if the bore diameter is increased to 7,2 cm and the compression ratio is increased to 10 : 1. The clearance volume remains unchanged.

Give the answer in mm. (7)



7.4 The following data was obtained when a four-stroke four-cylinder engine was tested:

| | |
|------------------------------|-------------|
| Engine rotational frequency: | 2 500 r/min |
| Mean effective pressure: | 1 250 kPa |
| Bore diameter: | 8 cm |
| Stroke length: | 10 cm |
| Brake power: | 46,08 kW |

Calculate the following:

- 7.4.1 Indicated power in kW (7)
- 7.4.2 Torque (4)
- 7.4.3 Mechanical efficiency (2)
- [32]**

QUESTION 8: MAINTENANCE (SPECIFIC)

- 8.1 State THREE exhaust gas analyser readings that indicate a lean fuel mixture. (3)
- 8.2 State THREE possible causes of high levels of hydrocarbon (HC) readings in the exhaust gas of an internal combustion engine. (3)
- 8.3 Tabulate TWO possible causes and their corrective measures when two adjacent cylinders have very low but similar readings when doing a compression test on a four-stroke internal combustion engine. (4)
- 8.4 State TWO causes of bubbles in the radiator water when a cylinder leakage test is conducted on an internal combustion engine. (2)
- 8.5 Name THREE manufacturer's specifications that must be obtained before conducting an oil pressure test. (3)
- 8.6 State FOUR precautions that must be adhered to while setting up the fuel pressure tester. (4)
- 8.7 The pressure dropped during a radiator pressure test. State FOUR measures to correct the pressure drop. (4)
- [23]**



QUESTION 9: SYSTEMS AND CONTROL (AUTOMATIC GEARBOX) (SPECIFIC)

9.1 FIGURE 9.1 below shows a lockup torque converter. Answer the questions that follow.

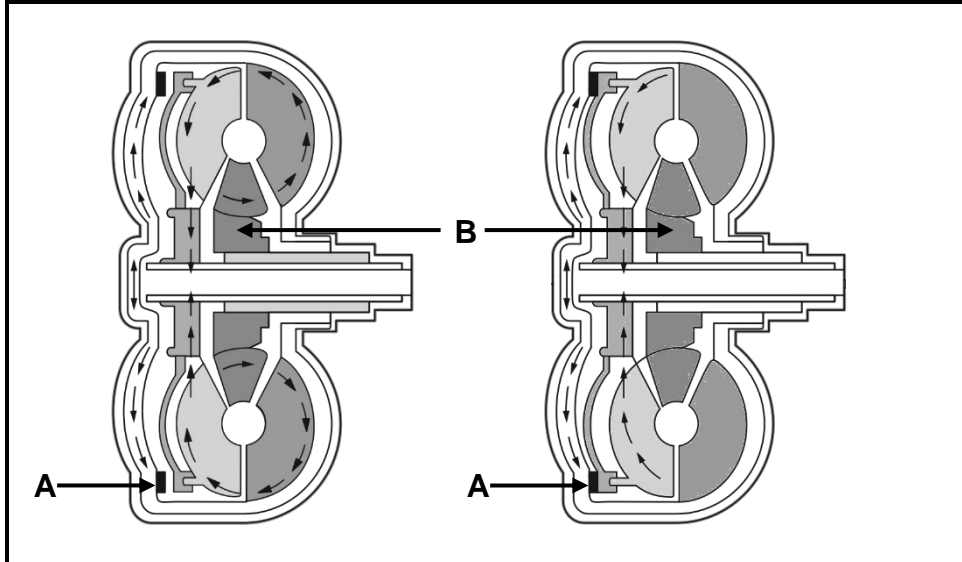

FIGURE 9.1

- 9.1.1 State TWO functions of the clutch friction surface **A**. (2)
- 9.1.2 State TWO functions of stator **B**. (2)
- 9.1.3 Explain how the lockup clutch engages in the torque converter. (5)

9.2 Study FIGURE 9.2 below and answer the questions that follow.

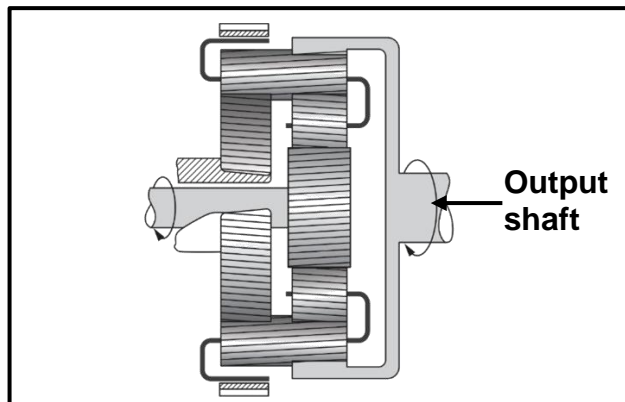

FIGURE 9.2

- 9.2.1 Identify the part of an automatic gearbox shown in FIGURE 9.2. (1)
- 9.2.2 How many forward and reverse gear selections are obtained using the configuration in FIGURE 9.2? (2)



- 9.3 Describe TWO methods of cooling the hydraulic transmission fluid in an automatic transmission. (2)
- 9.4 State TWO differences between the *construction of a manual transmission* and the *construction of an automatic transmission*. (4)

[18]

QUESTION 10: SYSTEMS AND CONTROL (AXLES, STEERING GEOMETRY AND ELECTRONICS) (SPECIFIC)

- 10.1 State THREE pre-checks performed on the vehicle suspension before wheel alignment adjustments and checks can be done. (3)
- 10.2 Draw a neat labelled sketch to explain *toe-out* when turning to the right. (6)
- 10.3 State TWO suspension faults that will negatively affect toe-out on turns. (2)
- 10.4 Explain the procedure to statically balance a wheel. (5)
- 10.5 The electronic control unit (ECU) controls many systems on a vehicle. State the functions of the following systems:
- 10.5.1 Air-induction system (2)
- 10.5.2 Ignition system (2)
- 10.6 Name the TWO toxic exhaust gases which are converted into non-toxic gases when it flows through the catalytic converter. (2)
- 10.7 Label **A–D** of the common rail direct injection (CRDI) system shown in FIGURE 10.7 below.

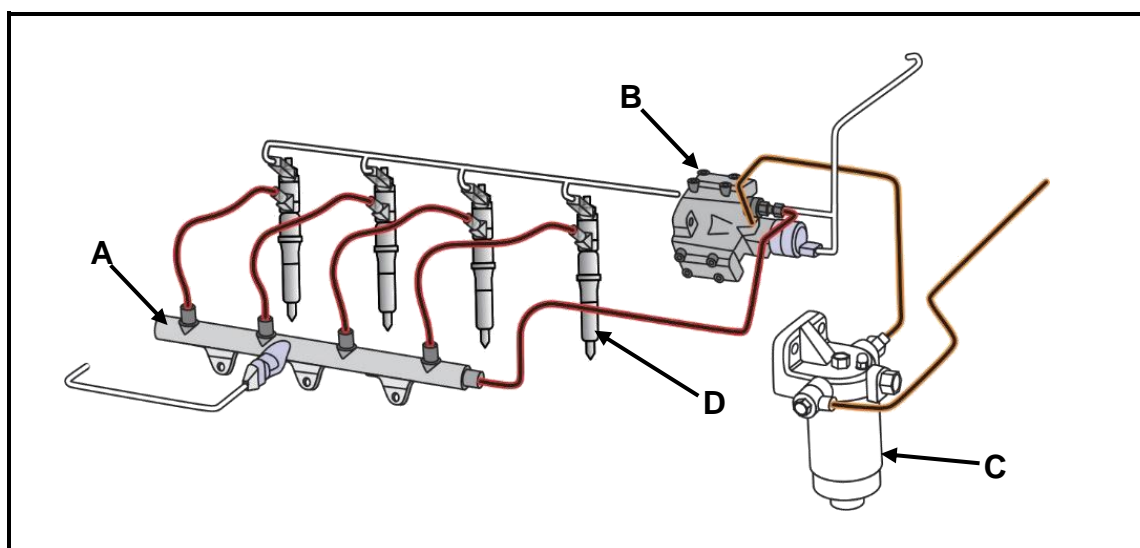

FIGURE 10.7

(4)



- 10.8 What is the function of the pressure regulator in the fuel system? (2)
- 10.9 FIGURE 10.9 below shows a three-phase alternator circuit diagram. Answer the questions that follow.

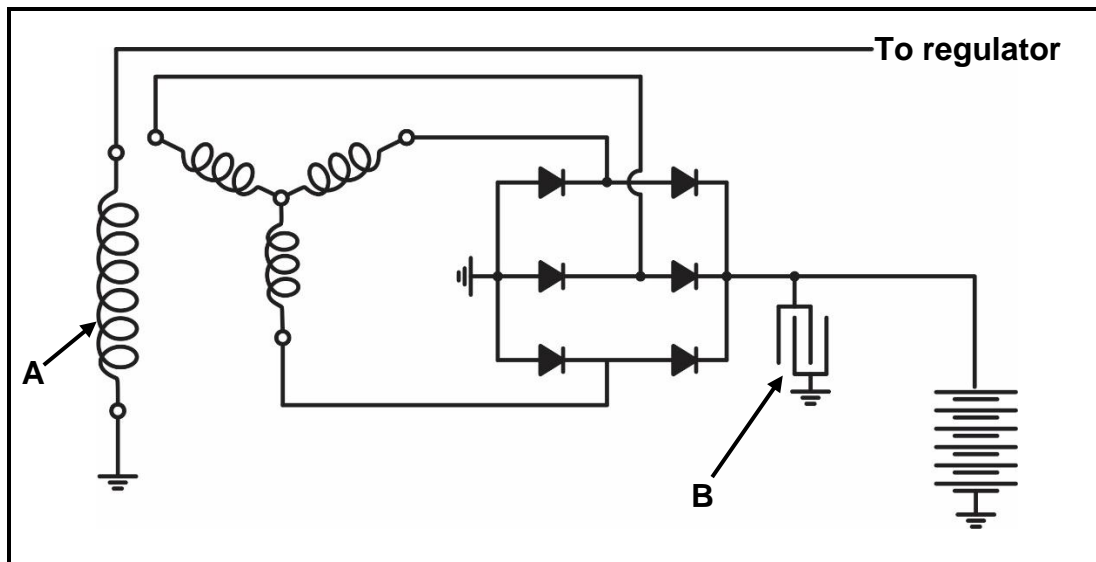

FIGURE 10.9

- 10.9.1 Label **A** and **B**. (2)
- 10.9.2 Which configuration is used to connect the stator windings? (1)
- 10.9.3 How many diodes are shown in the circuit? (1)
- [32]

TOTAL: 200



FORMULA SHEET FOR MECHANICAL TECHNOLOGY: AUTOMOTIVE

1. $F = m \times a$

Where:

m = mass

a = acceleration

2. Work done = Force \times Displacement OR $W = F \times s$

3. Power = $\frac{\text{Force} \times \text{Displacement}}{\text{Time}}$ OR $P = \frac{F \times s}{t}$

4. Torque = Force \times Radius OR $T = F \times r$

5. $IP = P \times L \times A \times N \times n$

Where:

IP = Indicated power

P = Mean effective pressure

L = Stroke length

A = Area of piston crown

N = Number of power strokes per second

n = Number of cylinders

6. $BP = 2 \pi NT$

Where:

BP = Brake power

N = Revolutions per second

T = Torque

7. Brake power with Prony brake = $2 \times \pi \times N \times F \times R$

Where:

BP = Brake power

N = Revolutions per second

F = Force

R = Brake arm length



8. Mechanical efficiency = $\frac{BP}{IP} \times 100\%$

9. Compression ratio = $\frac{SV + CV}{CV}$

Where:

SV = Swept volume

CV = Clearance volume

10. $SV = \frac{\pi D^2}{4} \times L$

Where:

D = Bore diameter

L = Stroke length

11. $CV = \frac{SV}{CR-1}$

12. Gear ratio = $\frac{\text{Product of teeth on driven gears}}{\text{Product of teeth on driver gears}}$

