



basic education

Department:
Basic Education
REPUBLIC OF SOUTH AFRICA

SENIOR CERTIFICATE EXAMINATIONS/ NATIONAL SENIOR CERTIFICATE EXAMINATIONS

ELECTRICAL TECHNOLOGY: ELECTRONICS

2022

MARKS: 200

TIME: 3 hours



**This question paper consists of 25 pages, a 1-page formula sheet
and 4 answer sheets.**

INSTRUCTIONS AND INFORMATION

1. This question paper consists of SIX questions.
2. Answer ALL the questions.
3. Answer the following questions on the attached ANSWER SHEETS:

QUESTIONS 4.2.1, 4.2.2, 4.3.3 and 4.7.3
QUESTIONS 5.3.5, 5.4.6, 5.6.1 and 5.6.2
QUESTION 6.5.3
4. Write your centre number and examination number on every ANSWER SHEET and hand them in with your ANSWER BOOK, whether you have used them or not.
5. Sketches and diagrams must be large, neat and FULLY LABELLED.
6. Show ALL calculations and round off answers correctly to TWO decimal places.
7. Number the answers correctly according to the numbering system used in this question paper.
8. You may use a non-programmable calculator.
9. Calculations must include:
 - 9.1 Formulae and manipulations where needed
 - 9.2 Correct replacement of values
 - 9.3 Correct answers and relevant units where applicable
10. A formula sheet is attached at the end of this question paper.
11. Write neatly and legibly.



QUESTION 1: MULTIPLE-CHOICE QUESTIONS

Various options are provided as possible answers to the following questions. Choose the answer and write only the letter (A–D) next to the question numbers (1.1.1 to 1.1.15) in the ANSWER BOOK, e.g. 1.16 D.

- 1.1 The layer(s) of the skin that is/are affected by a third-degree burn would be ...
- A the outer layer.
 - B the second layer.
 - C all layers of the skin.
 - D None of the above-mentioned (1)
- 1.2 The power factor in an RLC series circuit will be lagging if V_L ...
- A is greater than V_C .
 - B is less than V_C .
 - C is equal to V_C .
 - D None of the above-mentioned (1)
- 1.3 A circuit has a resistance of R ohm, inductance of L henry and a capacitance of C farad connected in series. The power factor of the circuit will be at unity (1) when ...
- A X_L is less than X_C .
 - B X_L is greater than X_C .
 - C $X_L = X_C$.
 - D $R = 0$. (1)
- 1.4 Which ONE of the following conditions exists in a resonant parallel RLC circuit?
- A The impedance is minimum.
 - B The impedance is maximum.
 - C The total current is maximum.
 - D The power factor is lagging. (1)
- 1.5 The ... is a device that relies on the creation of an electric field within the channel to control current flow.
- A Darlington pair transistor
 - B unijunction transistor
 - C field-effect transistor
 - D operational amplifier (1)



- 1.6 When applying a signal to the inverting input of an op amp, phase shift is achieved by the ...
- A cut-off frequency.
 - B internal amplifier circuits.
 - C notch frequency.
 - D unity-gain frequency. (1)
- 1.7 Negative feedback in an op amp ...
- A increases the input and output impedances.
 - B decreases the output impedance and the bandwidth.
 - C increases the input impedance and the bandwidth.
 - D does not affect impedances or the bandwidth. (1)
- 1.8 Open-loop gain with reference to op amps is when ...
- A a feedback resistor is connected from the output to the inverting input.
 - B no feedback resistor is connected from the output to the input.
 - C a capacitor is connected from the output to the inverting input.
 - D a feedback resistor is connected from the output to the non-inverting input. (1)
- 1.9 When a triangular waveform is applied to the input of a differentiator, the output waveform will be a/an ...
- A DC level.
 - B inverted triangular waveform.
 - C first harmonic frequency of the triangular waveform.
 - D square waveform. (1)
- 1.10 The basic circuit of a passive RC differentiator is a ...
- A capacitor in series with the input and a resistor in parallel with the output.
 - B resistor in series with the input and a capacitor in parallel with the output.
 - C resistor in series with the input and a resistor in parallel with the output.
 - D capacitor in series with the input and a capacitor in parallel with the output. (1)



- 1.11 A/An ... circuit is used to clean up an input signal which has been distorted.
- A integrator
 - B differentiator
 - C Schmitt trigger
 - D comparator
- (1)
- 1.12 In a class C amplifier, the output collector current will flow through the transistor for ... of the input cycle.
- A more than 180°
 - B 90°
 - C 360°
 - D less than 180°
- (1)
- 1.13 The operation of a relaxation oscillator is based on ...
- A the charging and discharging of a capacitor.
 - B a highly selective resonant circuit.
 - C a very stable supply voltage.
 - D lower power consumption.
- (1)
- 1.14 For an oscillator to maintain oscillation, the gain must be ...
- A 1.
 - B less than 1.
 - C greater than 1.
 - D equal to β .
- (1)
- 1.15 A bipolar junction transistor class B push-pull amplifier with no transformer coupling uses ...
- A two NPN transistors.
 - B two PNP transistors.
 - C one NPN transistor.
 - D complementary symmetrical transistors.
- (1)

[15]

QUESTION 2: OCCUPATIONAL HEALTH AND SAFETY

- 2.1 Explain the term *machinery* with reference to the Occupational Health and Safety Act, 1993 (Act 85 of 1993). (2)
- 2.2 Explain the term *critical incident* with regard to emergencies. (2)
- 2.3 State TWO steps you should take when you discover a fire in an electrical workshop. (2)
- 2.4 State the importance of wearing a face mask in the workshop. (2)
- 2.5 Name TWO environmental considerations when working with chemicals during the printed circuit board manufacturing process. (2)

[10]

QUESTION 3: RLC CIRCUITS

- 3.1 Define a *phasor diagram* with reference to RLC circuits connected across an alternating voltage supply. (2)
- 3.2 FIGURE 3.2 below shows an RLC series circuit which consists of a resistor with a resistance of 10Ω , an inductor with an inductive reactance of 14Ω and a capacitor with a capacitive reactance of 8Ω , all connected across an alternating supply of 100 Hz .

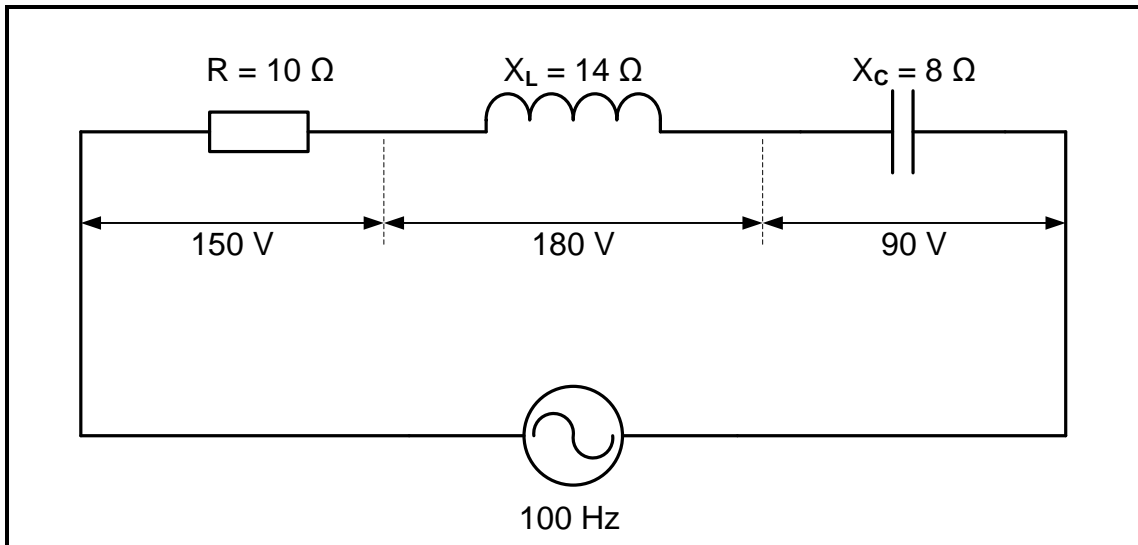
**FIGURE 3.2: SERIES RLC CIRCUIT**

Given:

$$\begin{aligned} R &= 10 \Omega \\ X_C &= 8 \Omega \\ X_L &= 14 \Omega \\ V_R &= 150 \text{ V} \\ V_L &= 180 \text{ V} \\ V_C &= 90 \text{ V} \\ f &= 100 \text{ Hz} \end{aligned}$$

- 3.2.1 Calculate the total supply voltage applied to the circuit. (3)
- 3.2.2 Discuss whether the power factor will be leading or lagging. (3)



3.3 Refer to FIGURE 3.3 below and answer the questions that follow.

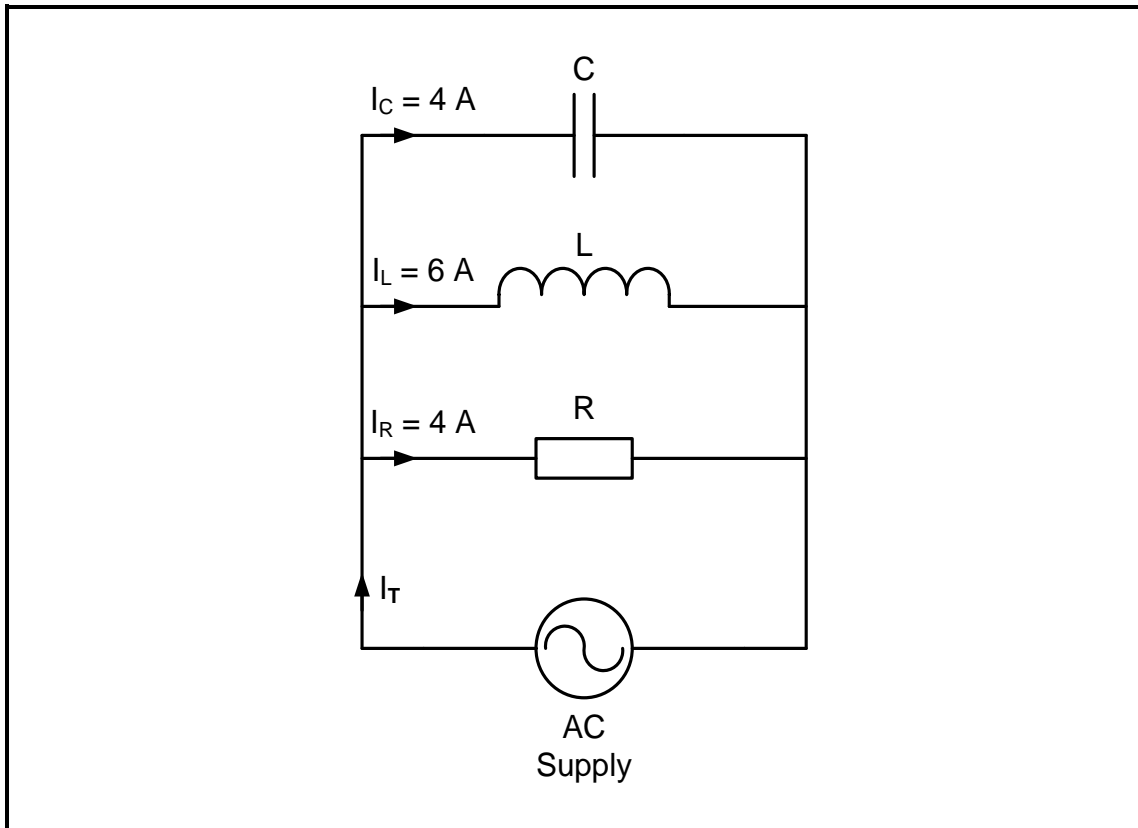

FIGURE 3.3: PARALLEL RLC CIRCUIT

Given:

$$I_C = 4 \text{ A}$$

$$I_L = 6 \text{ A}$$

$$I_R = 4 \text{ A}$$

3.3.1 Calculate the total current. (3)

3.3.2 Calculate the phase angle. (3)

3.3.3 Draw the phasor diagram for FIGURE 3.3. (4)

3.3.4 Motivate with a reason if the circuit is predominately capacitive or inductive. (2)



3.4 Refer to FIGURE 3.4 below and answer the questions that follow.

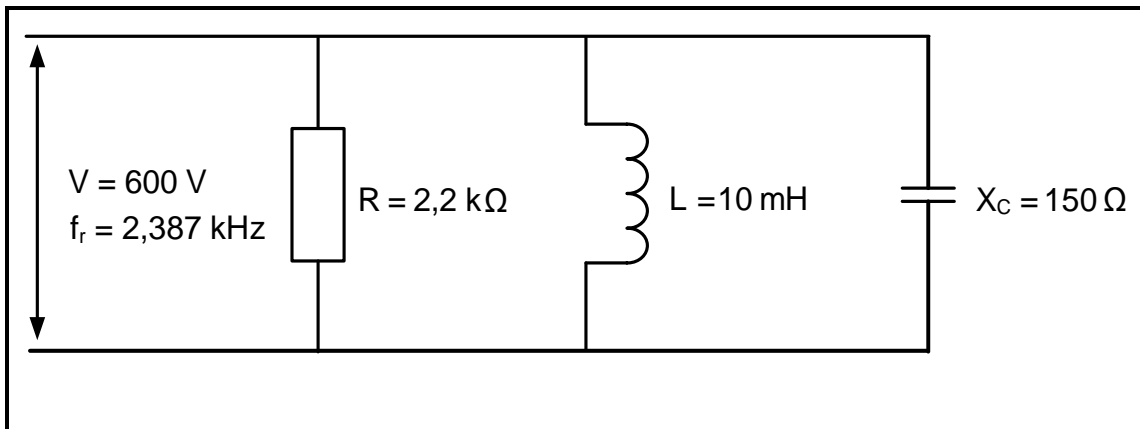

FIGURE 3.4: RESONANT RLC CIRCUIT

- 3.4.1 Calculate the quality factor of the circuit. (3)
- 3.4.2 Calculate the bandwidth. (3)
- 3.4.3 Calculate the value of the capacitor. (3)
- 3.4.4 Define the term *selectivity* with reference to resonant circuits. (2)

3.5 Refer to FIGURE 3.5 below and answer the questions that follow.

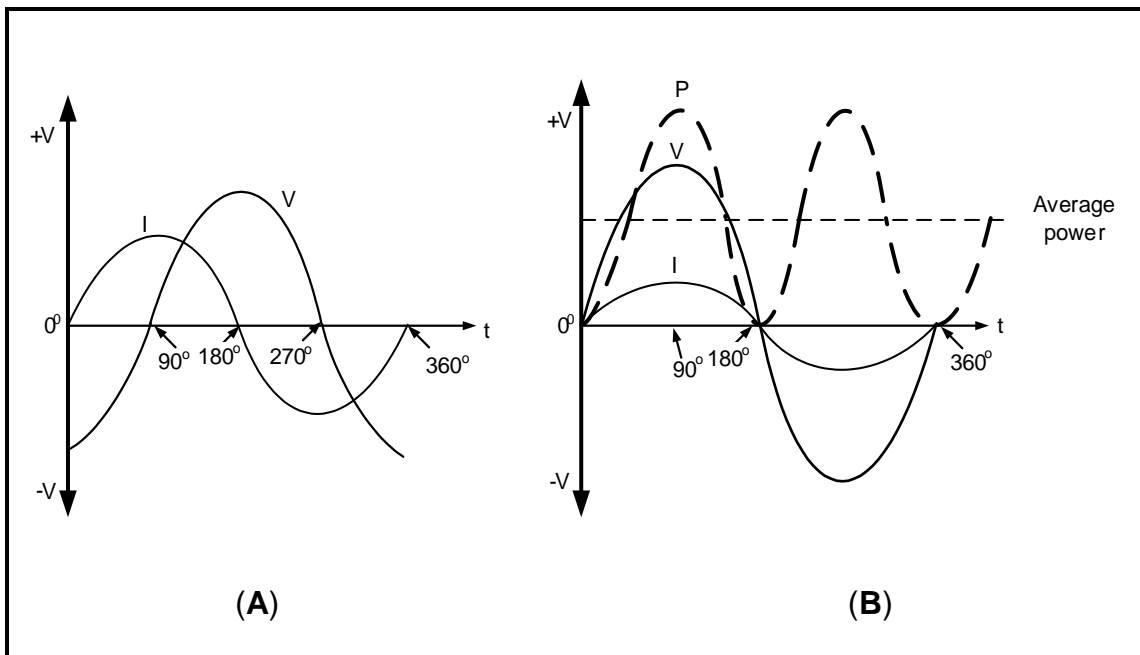

FIGURE 3.5: CURRENT, VOLTAGE AND POWER WAVEFORMS

- 3.5.1 State with a reason the type of component that produces the waveform in FIGURE 3.5 (A). (2)
- 3.5.2 Identify the component across which power is dissipated in FIGURE 3.5 (B). Motivate your answer. (2)

[35]



QUESTION 4: SEMICONDUCTORS

- 4.1 Draw a fully labelled IEC symbol of a unijunction transistor. (3)
- 4.2 Refer to FIGURE 4.2 below and answer the questions that follow.

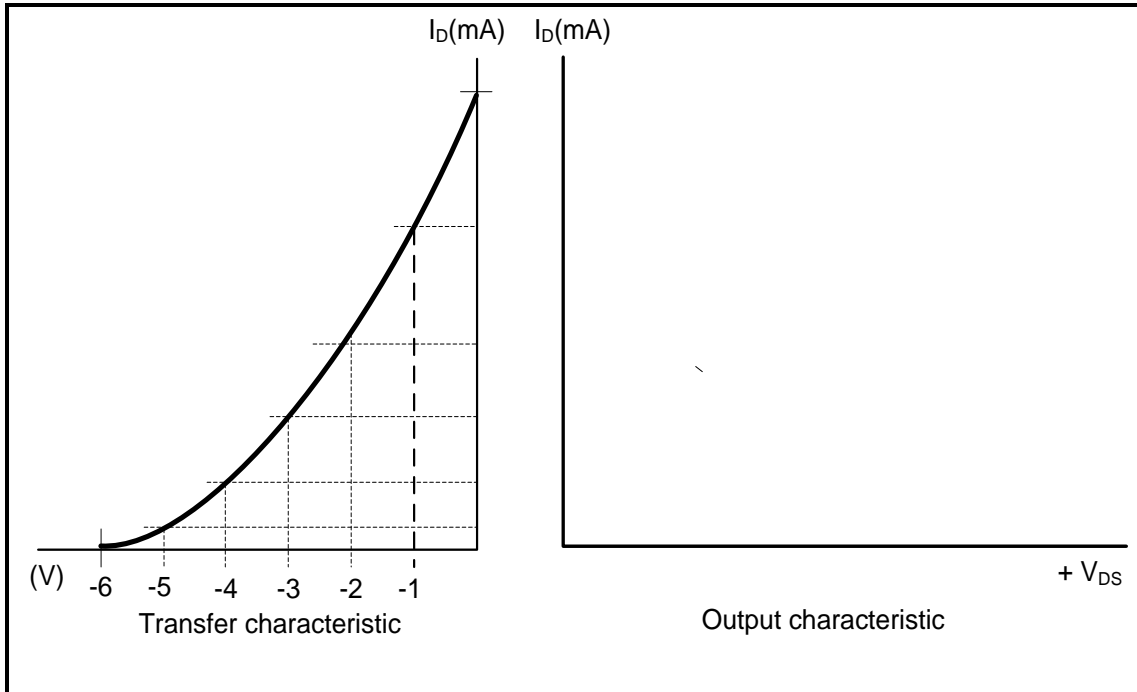

FIGURE 4.2: TRANSFER CHARACTERISTIC OF JFET

- 4.2.1 Draw a fully labelled output characteristic curve of the n-channel junction field-effect transistor (JFET) for the given transfer characteristic shown in FIGURE 4.2 on the ANSWER SHEET for QUESTION 4.2.1. (3)
- 4.2.2 On the ANSWER SHEET for QUESTION 4.2.2, indicate the pinch-off voltage on the output characteristic curve if $V_{GS} = -1 \text{ V}$. (1)



4.3 Refer to FIGURE 4.3 below and answer the questions that follow.

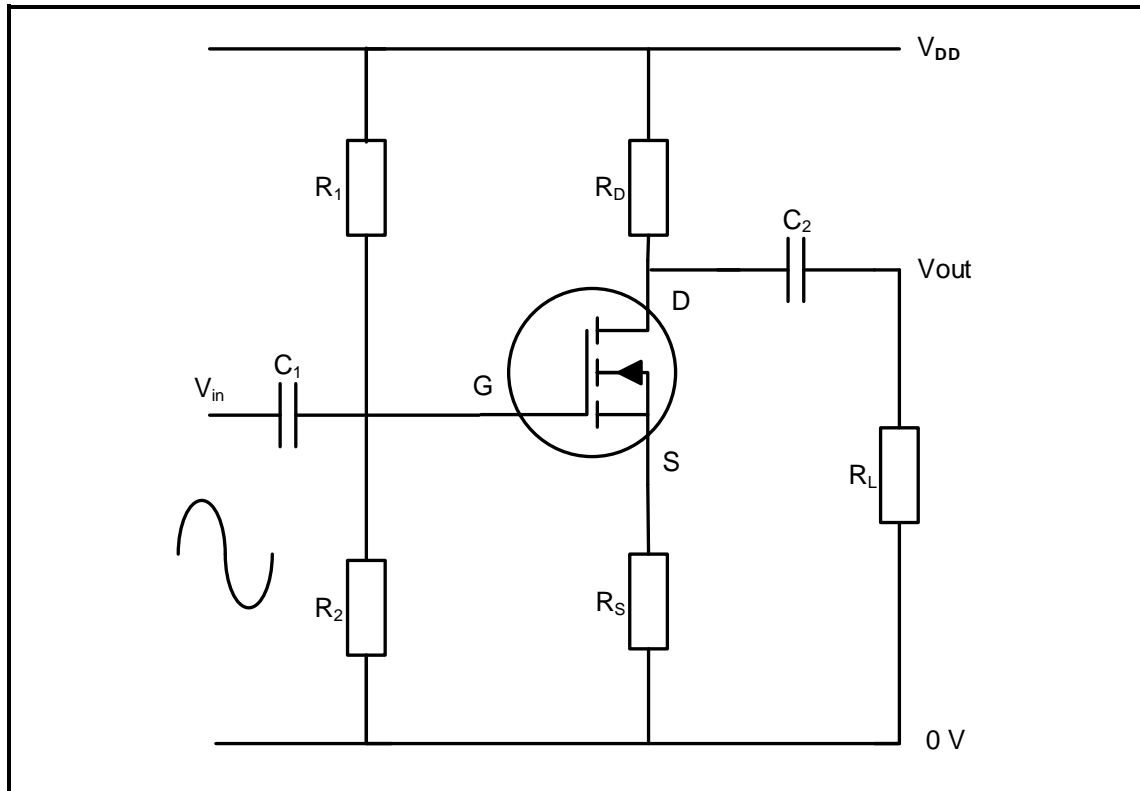

FIGURE 4.3: AMPLIFIER CIRCUIT DIAGRAM

- 4.3.1 Identify the amplifier circuit diagram in FIGURE 4.3. (2)
- 4.3.2 Describe how the circuit will be able to amplify the input signal as a linear amplifier. (3)
- 4.3.3 Complete the input transfer characteristic curve of the circuit diagram in FIGURE 4.3 by using the information provided on the ANSWER SHEET for QUESTION 4.3.3. (3)



4.4 Refer to FIGURE 4.4 below and answer the questions that follow.

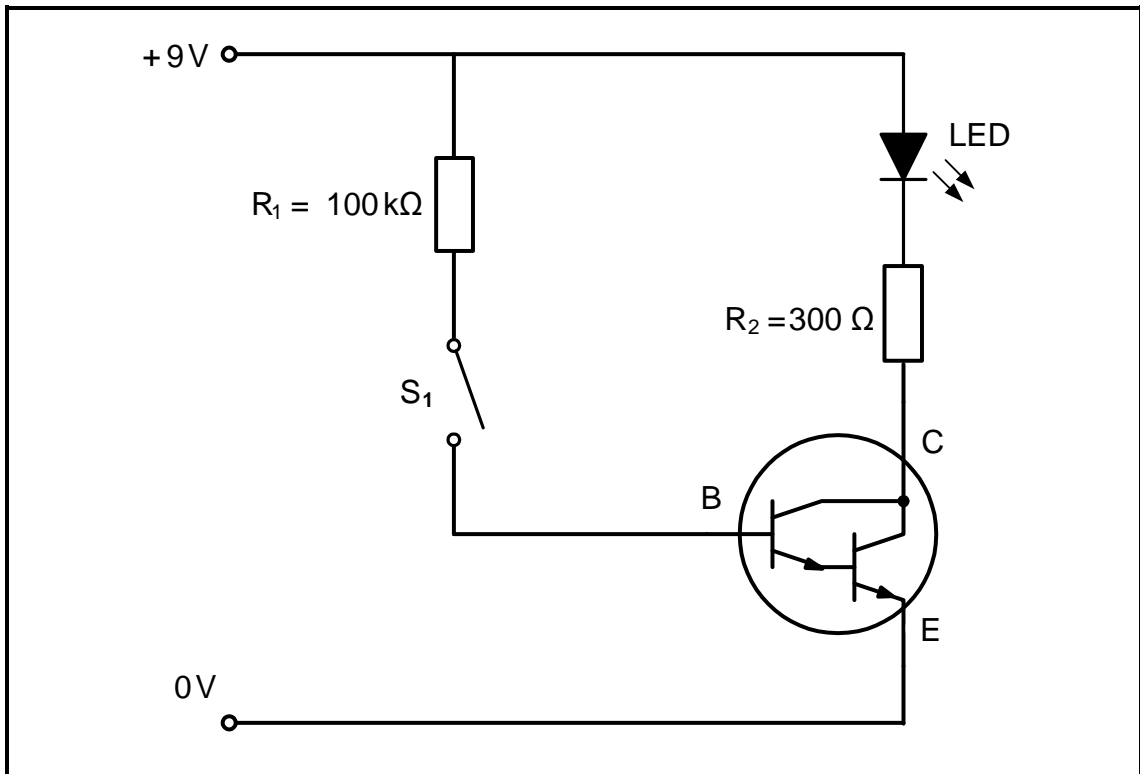

FIGURE 4.4: TRANSISTOR CIRCUIT DIAGRAM

- 4.4.1 Identify the application of the transistor circuit diagram in FIGURE 4.4. (1)
- 4.4.2 Briefly describe the operation of the circuit when the switch is closed. (3)

4.5 Refer to FIGURE 4.5 below and answer the questions that follow.

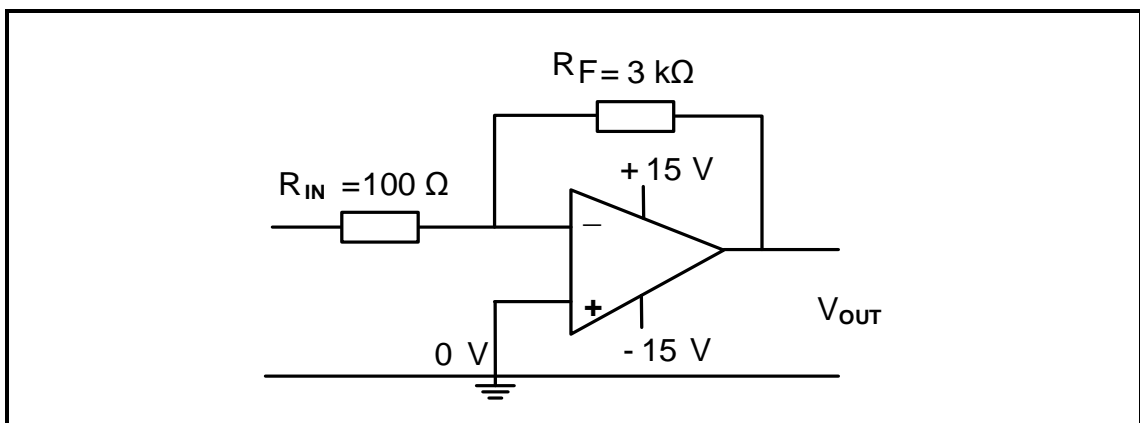

FIGURE 4.5: INVERTING OP AMP

- 4.5.1 State why the circuit is called an inverting op amp. (1)
- 4.5.2 Explain how the gain of the op amp is controlled. (2)
- 4.5.3 Calculate the gain of the op amp. (3)



4.6 FIGURE 4.6 below shows the 555 IC. Answer the questions that follow.

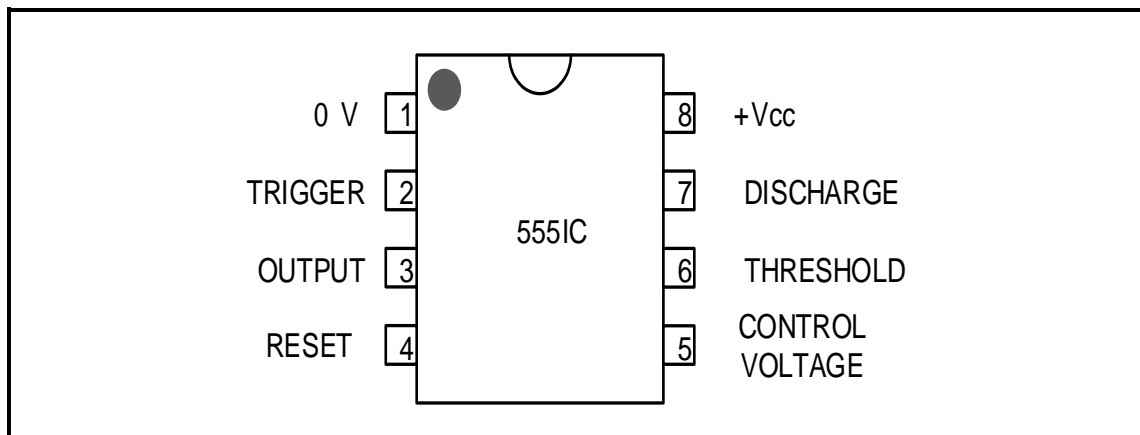

FIGURE 4.6: 555 IC PIN LAYOUT

- 4.6.1 Briefly describe the functions of pin 6 with reference to the 555 IC. (3)
- 4.6.2 State the supply voltage range at which the 555 IC operates. (2)
- 4.6.3 Explain the function of the SR flip-flop in the internal circuit of the 555 timer. (2)



4.7 Refer to FIGURE 4.7 below and answer the questions that follow.

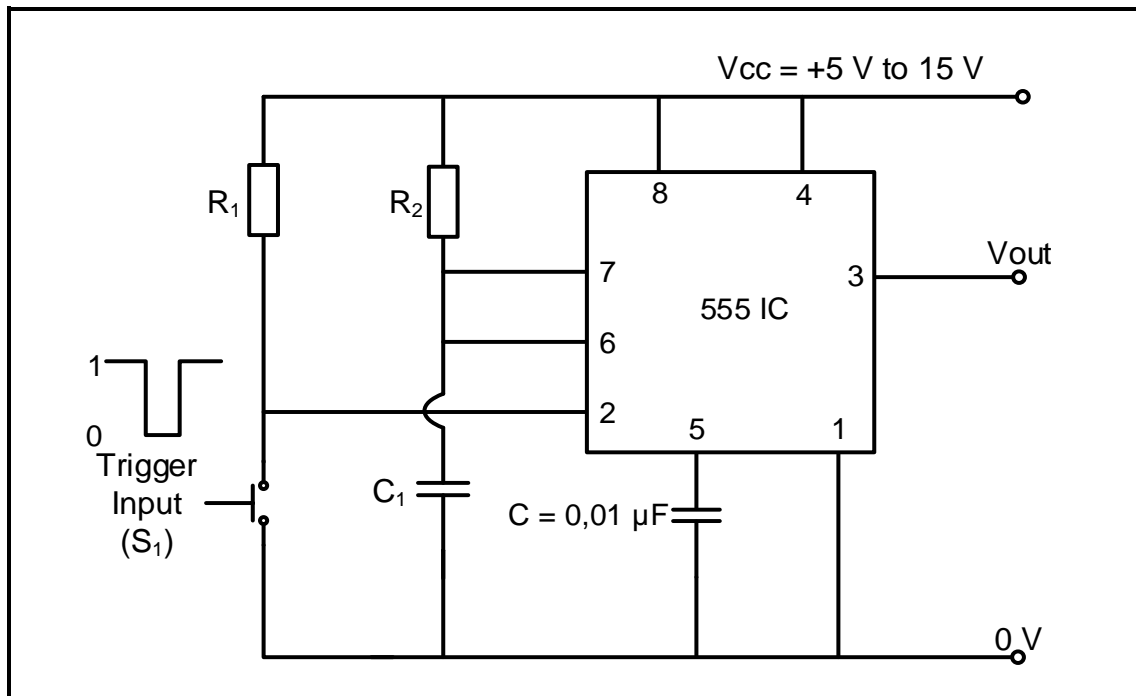

FIGURE 4.7: 555 IC MULTIVIBRATOR

- 4.7.1 Identify the multivibrator in FIGURE 4.7. (1)
- 4.7.2 Give a brief description of what happens when the push-to-make switch (S_1) is activated. (4)
- 4.7.3 Draw on the ANSWER SHEET for QUESTION 4.7.3 the voltage waveform of the capacitor C_1 and the output voltage waveform when the trigger input is pressed. (4)



4.8 Refer to FIGURE 4.8 below which has an output frequency of 1 hertz and answer the questions that follow.

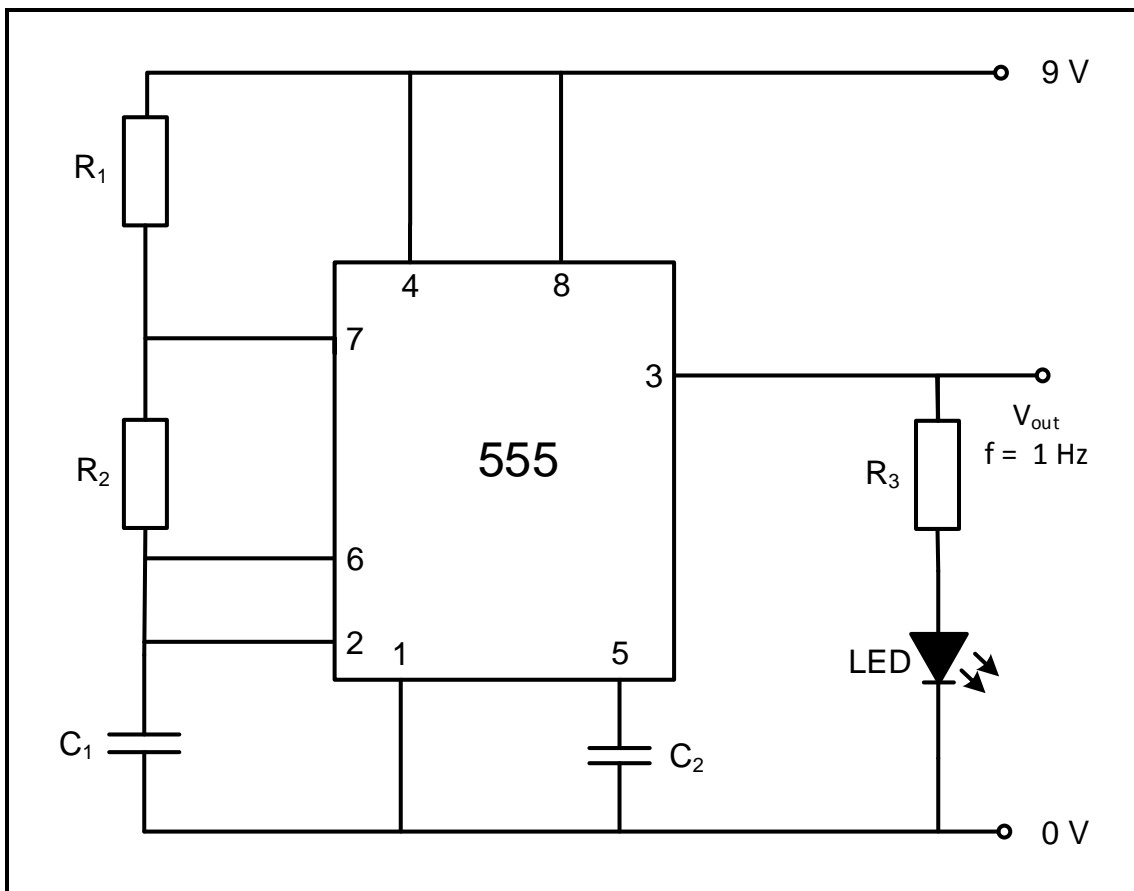

FIGURE 4.8: ASTABLE MULTIVIBRATOR

- 4.8.1 Explain the mode (state) of the LED. (2)
- 4.8.2 Explain the effect on the LED when:
 - (a) R_2 is halved (1)
 - (b) The value of C_1 is doubled (1)

[45]



QUESTION 5: SWITCHING CIRCUITS

5.1 Name the type of multivibrator that:

5.1.1 Produces one pulse cycle of 'high' and 'low' when a trigger pulse is applied to its input (1)

5.1.2 Changes state when a trigger pulse is applied and remains in that state (1)

5.2 Refer to FIGURE 5.2 below and answer the questions that follow.

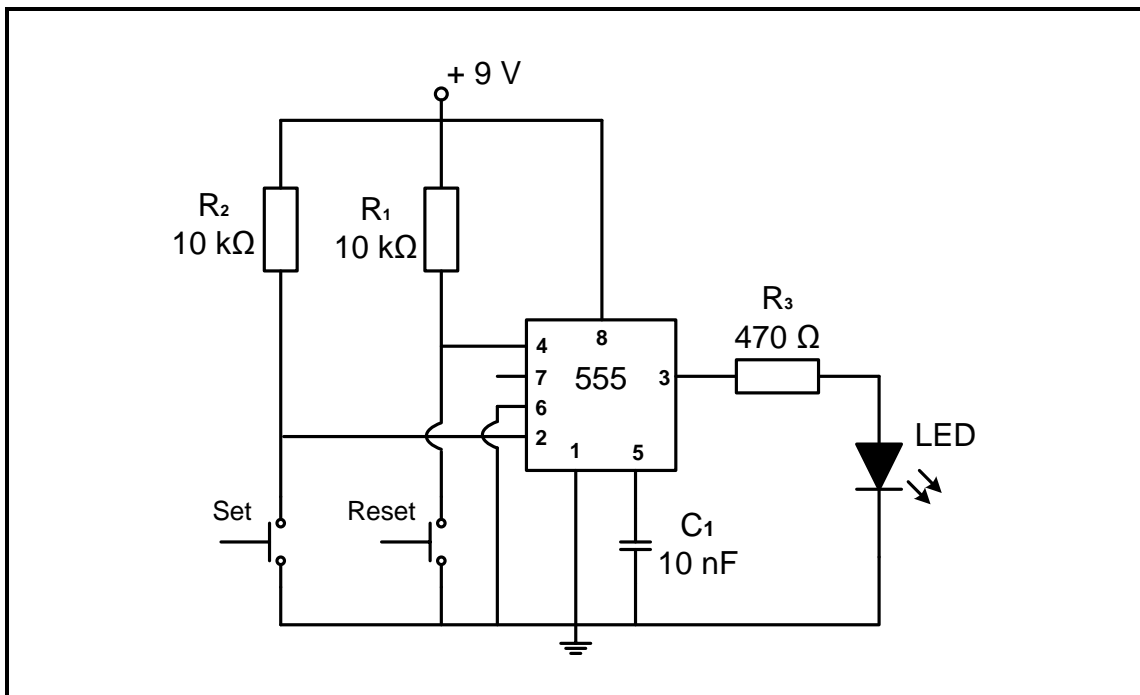

FIGURE 5.2: BI-STABLE MULTIVIBRATOR

5.2.1 Name the function of resistors:

(a) R_1 (1)

(b) R_3 (1)

5.2.2 Identify the state of the LED when trigger pin 2 is high. (1)

5.2.3 Explain what happens in the circuit when the set switch is pressed. (2)

5.2.4 Explain the purpose of connecting pin 6 to ground. (2)



5.3 FIGURE 5.3 below shows an op amp as a comparator. The resistance of the LDR increases as the level of light falls.

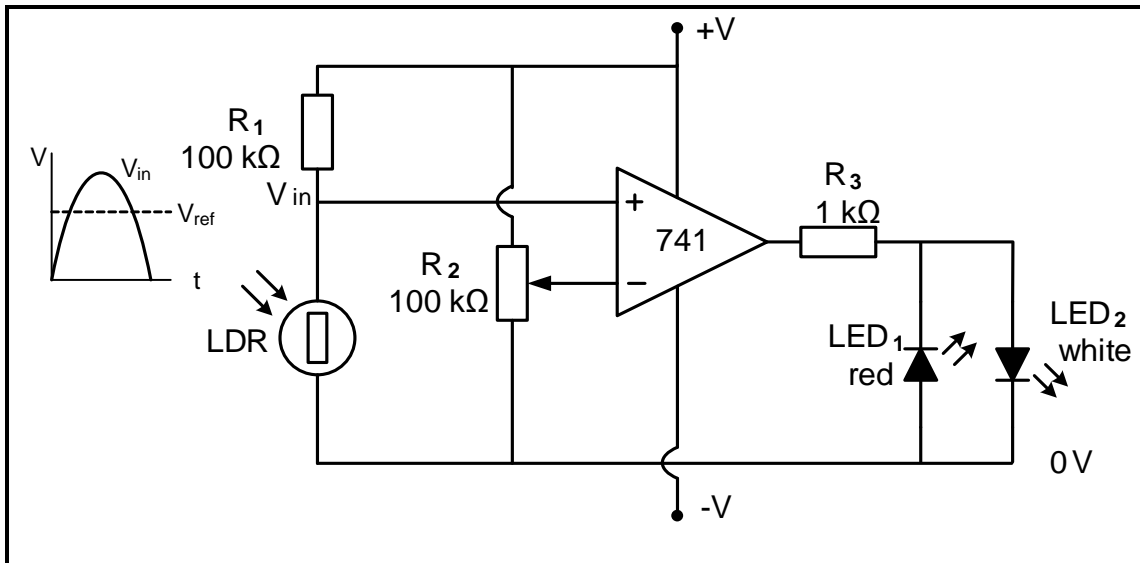

FIGURE 5.3: OP AMP COMPARATOR AS A DARK SENSOR

- 5.3.1 State the purpose of R_2 . (1)
- 5.3.2 Explain how an increase in the level of light affects the voltage on the non-inverting input. (2)
- 5.3.3 Explain the operation of the circuit with reference to the voltages on the input terminals and the output voltage. (3)
- 5.3.4 Predict the state of LED_1 and LED_2 when the voltage on the inverting terminal is higher than the voltage on the non-inverting terminal. (2)
- 5.3.5 Draw the output on the ANSWER SHEET for QUESTION 5.3.5. (3)



5.4 Refer to FIGURE 5.4 below and answer the questions that follow.

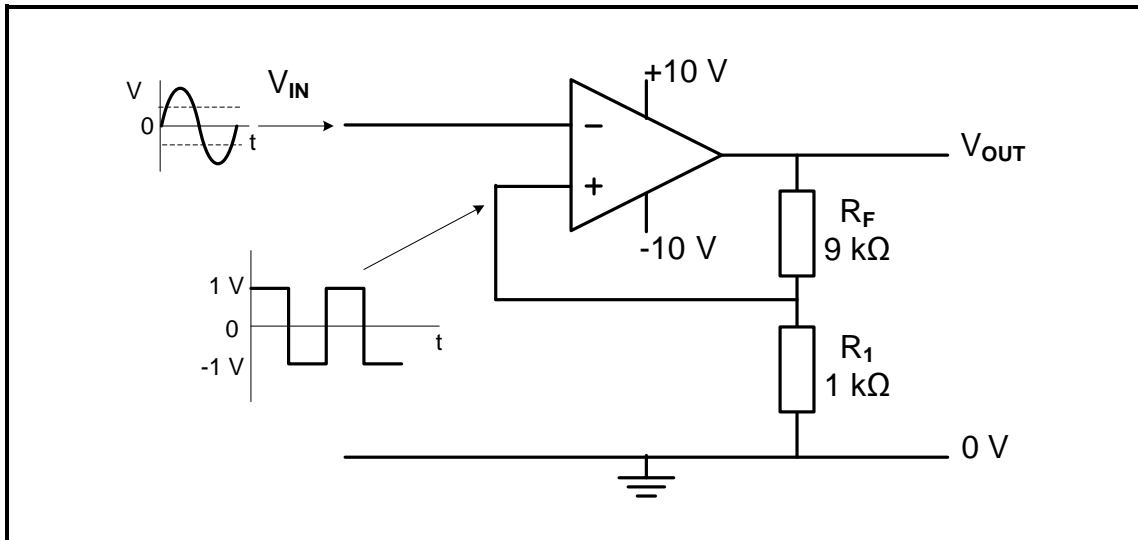

FIGURE 5.4: SCHMITT TRIGGER

- 5.4.1 Identify the type of Schmitt trigger circuit. (1)
- 5.4.2 Determine the value of the output voltage when the voltage on the non-inverting input is -1 V. (1)
- 5.4.3 State whether this circuit uses positive or negative feedback. (1)
- 5.4.4 Explain the operation of the circuit with reference to the input and trigger voltage levels. (4)
- 5.4.5 Predict how an increase in the value of R_1 will affect the trigger voltage level. (1)
- 5.4.6 Draw the output signal on the ANSWER SHEET for QUESTION 5.4.6. (4)



5.5 Refer to FIGURE 5.5 below and answer the questions that follow.

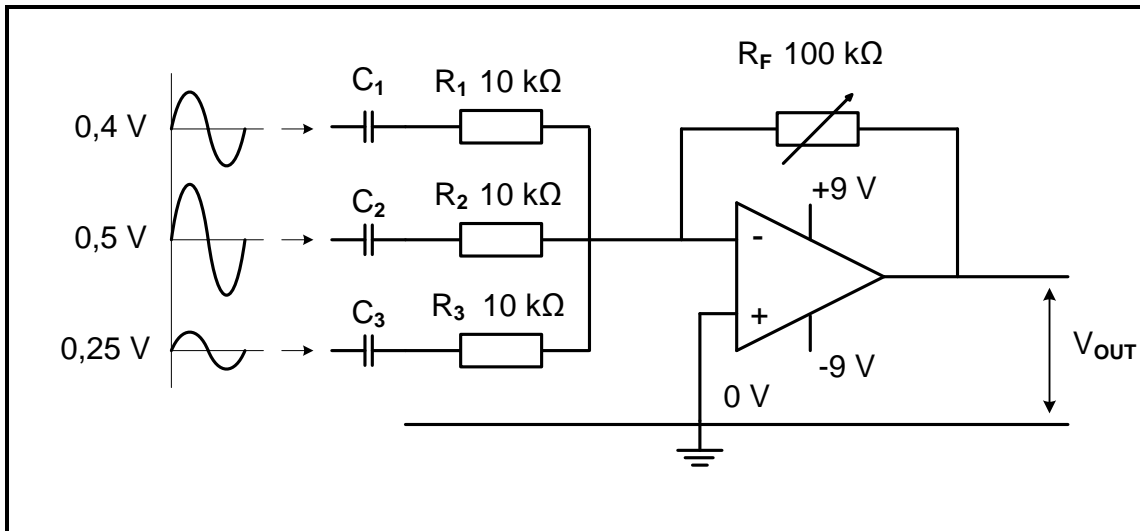

FIGURE 5.5: SUMMING AMPLIFIER

- 5.5.1 The variable resistor R_F serves a dual purpose. Name both purposes. (2)
- 5.5.2 Calculate the output voltage when the value of R_F is set to 78,26 kΩ. (3)
- 5.5.3 Explain how an increase in the value of R_F affects the gain of the amplifier. (1)
- 5.5.4 Describe why it is not recommended to increase the value of R_F beyond 78,26 kΩ. (4)
- 5.5.5 Explain how this limitation can be overcome without changing the value of any of the resistors. (2)

5.6 Refer to FIGURE 5.6 below and answer the questions that follow.

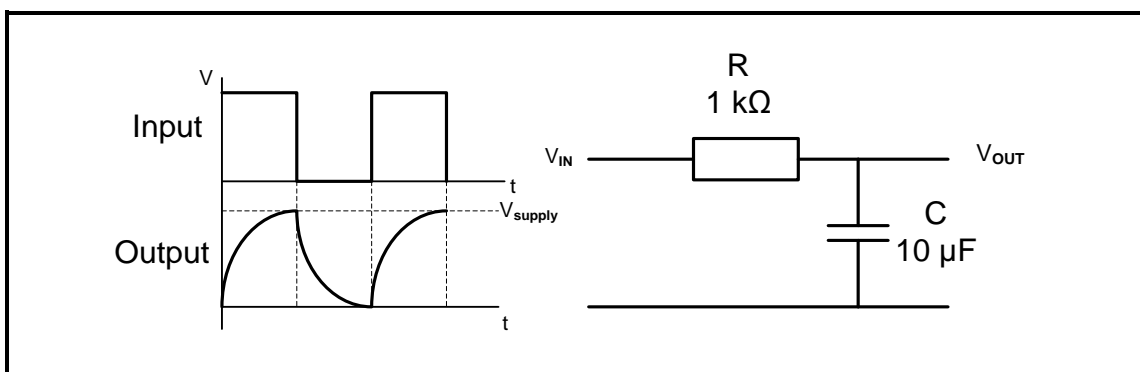

FIGURE 5.6: PASSIVE RC INTEGRATOR

- 5.6.1 Draw the output when the value of C is changed to 1 μF on the ANSWER SHEET for QUESTION 5.6.1. (3)
- 5.6.2 Draw the output when the value of C is changed to 100 μF on the ANSWER SHEET for QUESTION 5.6.2. (3)

[50]



QUESTION 6: AMPLIFIERS

- 6.1 Describe the term *linear amplifier* with reference to amplifiers. (2)
- 6.2 Name ONE consideration when determining the amplifier class. (1)
- 6.3 Refer to FIGURE 6.3 below and answer the questions that follow.

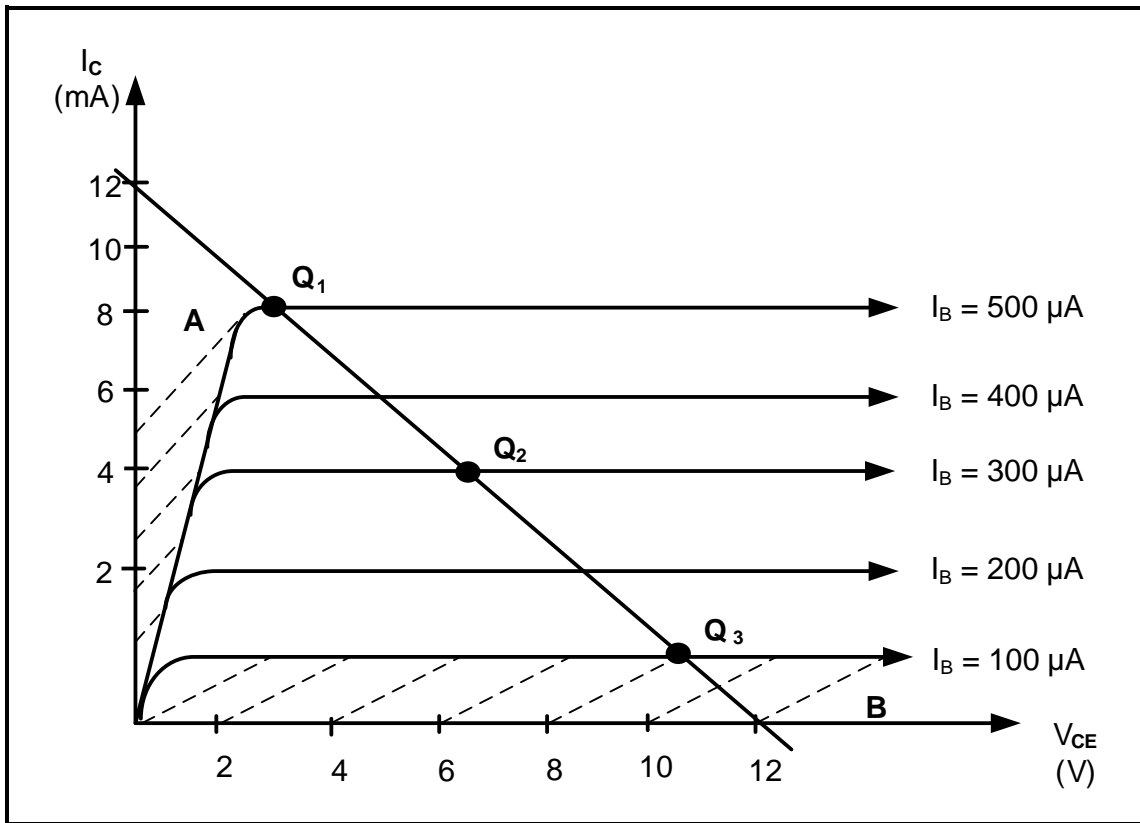

FIGURE 6.3: DC LOAD LINE

- 6.3.1 In which region (**A** or **B**) does the saturation point of the biased transistor occur? (1)
- 6.3.2 At which **Q**-point would class AB amplifiers be represented along the DC load line? (1)
- 6.3.3 Name ONE condition that affects the quiescent voltages and quiescent currents at Q_3 . (1)
- 6.4 Briefly explain how class B amplifiers operate. (2)



6.5 Refer to FIGURE 6.5 below and answer the questions that follow.

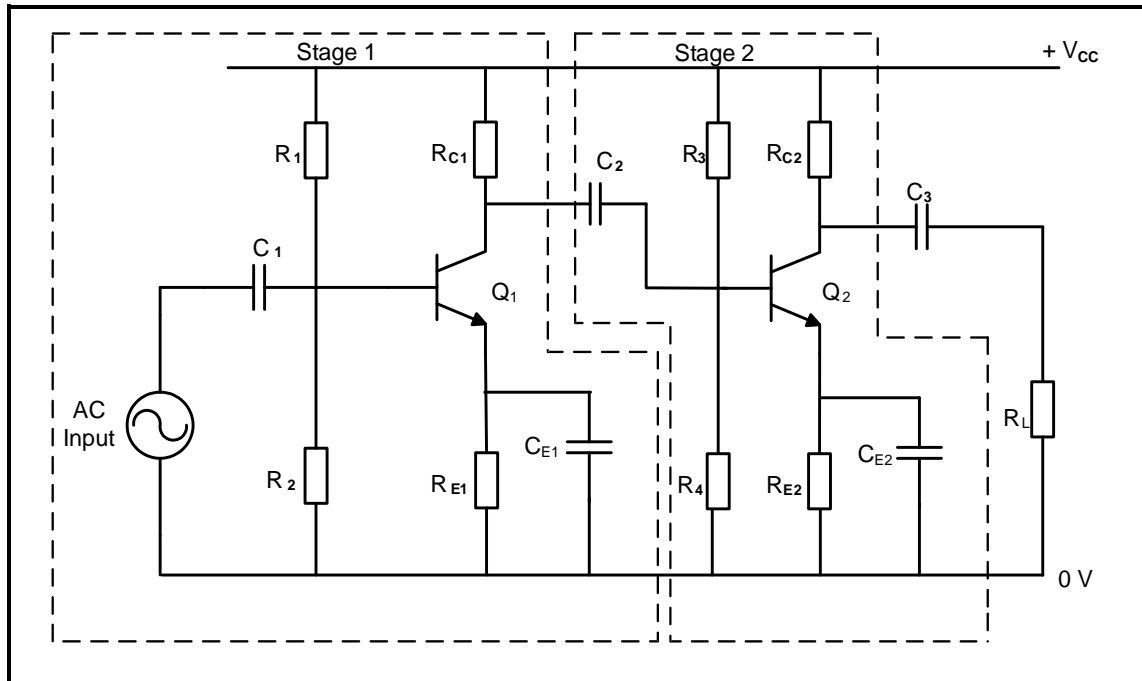

FIGURE 6.5: TWO-STAGE RC-COUPLED AMPLIFIER

- 6.5.1 State the purpose of using multi-stages in amplifiers. (1)
- 6.5.2 Calculate the total voltage gain in decibel of the circuit diagram if stage 1 has a voltage gain of 10 and stage 2 has a voltage gain of 15. (5)
- 6.5.3 Draw the output waveform across the load on the ANSWER SHEET for QUESTION 6.5.3. (3)



6.6 Refer to FIGURE 6.6 below and answer the questions that follow.

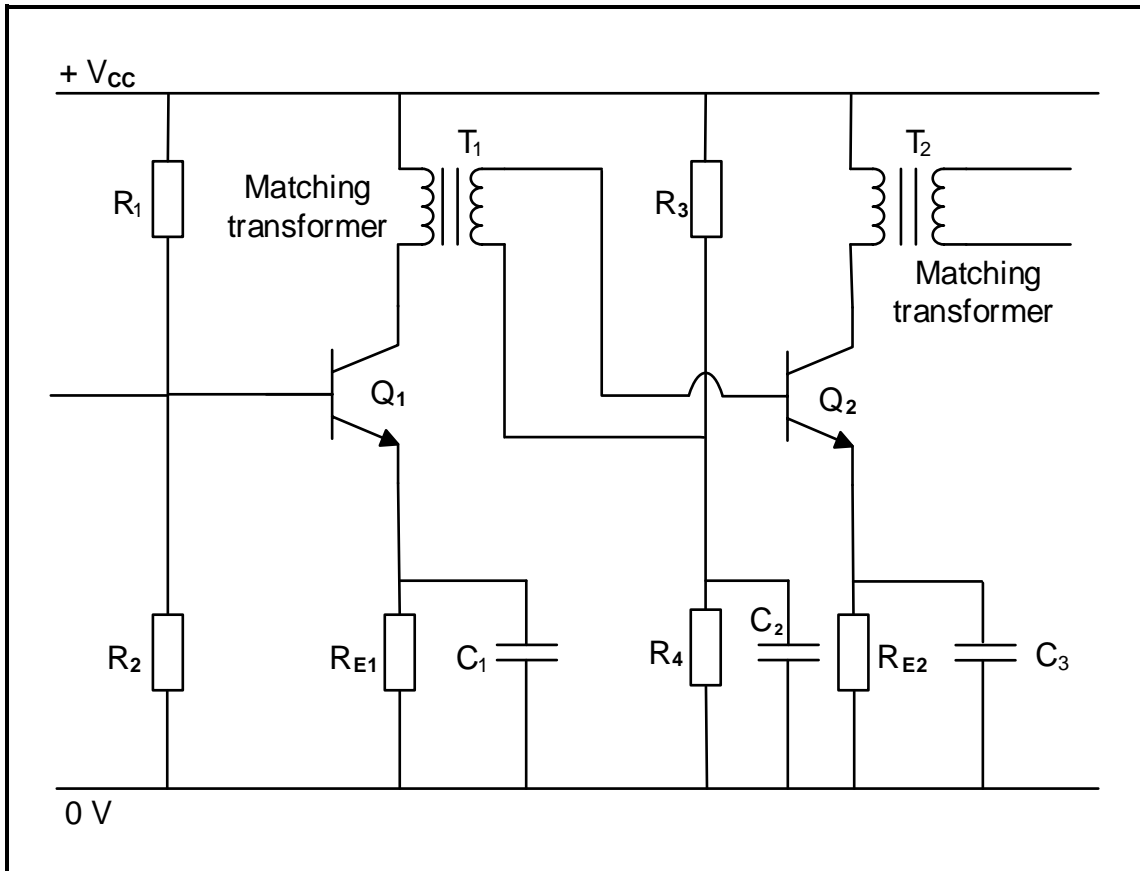

FIGURE 6.6: TRANSFORMER COUPLED AMPLIFIER

- 6.6.1 State the function of capacitor (C_2) connected across resistor R_4 . (2)
- 6.6.2 Name ONE advantage of a transformer coupled amplifier. (1)
- 6.6.3 Explain why it is preferable to connect the load via an output transformer (T_2). (2)



6.7 Refer to FIGURE 6.7 below and answer the questions that follow.

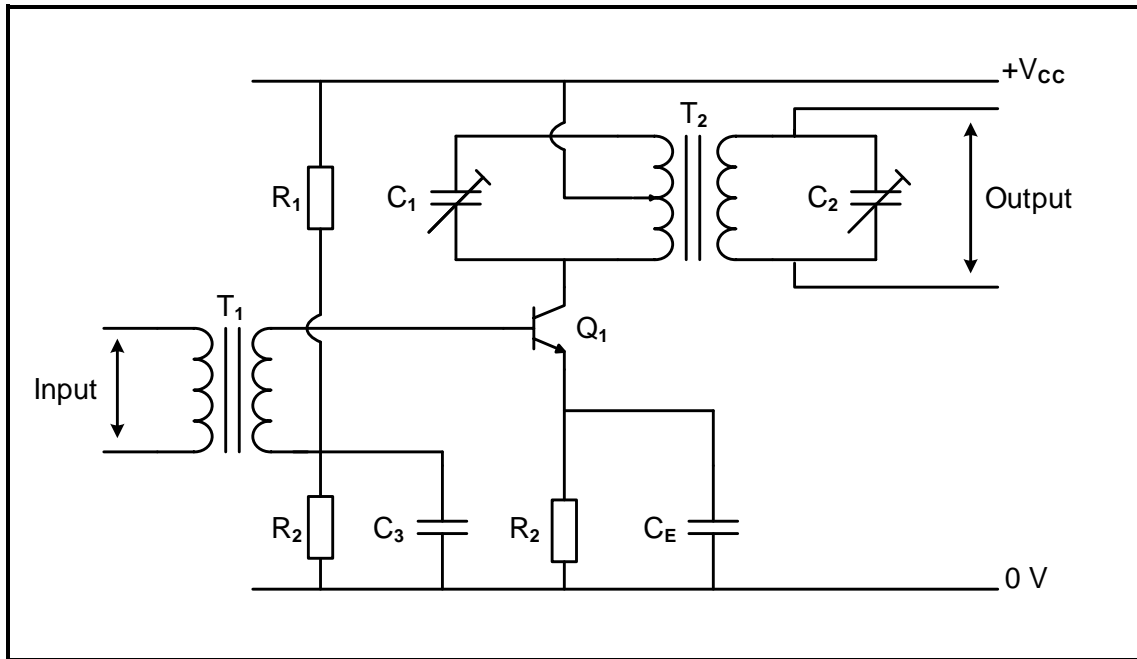

FIGURE 6.7: AMPLIFIER CIRCUIT DIAGRAM

- 6.7.1 Identify the amplifier in FIGURE 6.7. (1)
- 6.7.2 Describe the basic operation of the amplifier circuit. (2)
- 6.7.3 Give a reason why capacitor C_2 is connected across the secondary coil of transformer T_2 . (2)

6.8 The power of an amplifier is 200 mW at a frequency of 20 kHz. When the frequency increases to 30 kHz, the power decreases to 100 mW. Calculate the power loss of the system in decibel. (3)



6.9 Refer to FIGURE 6.9 below and answer the questions that follow.

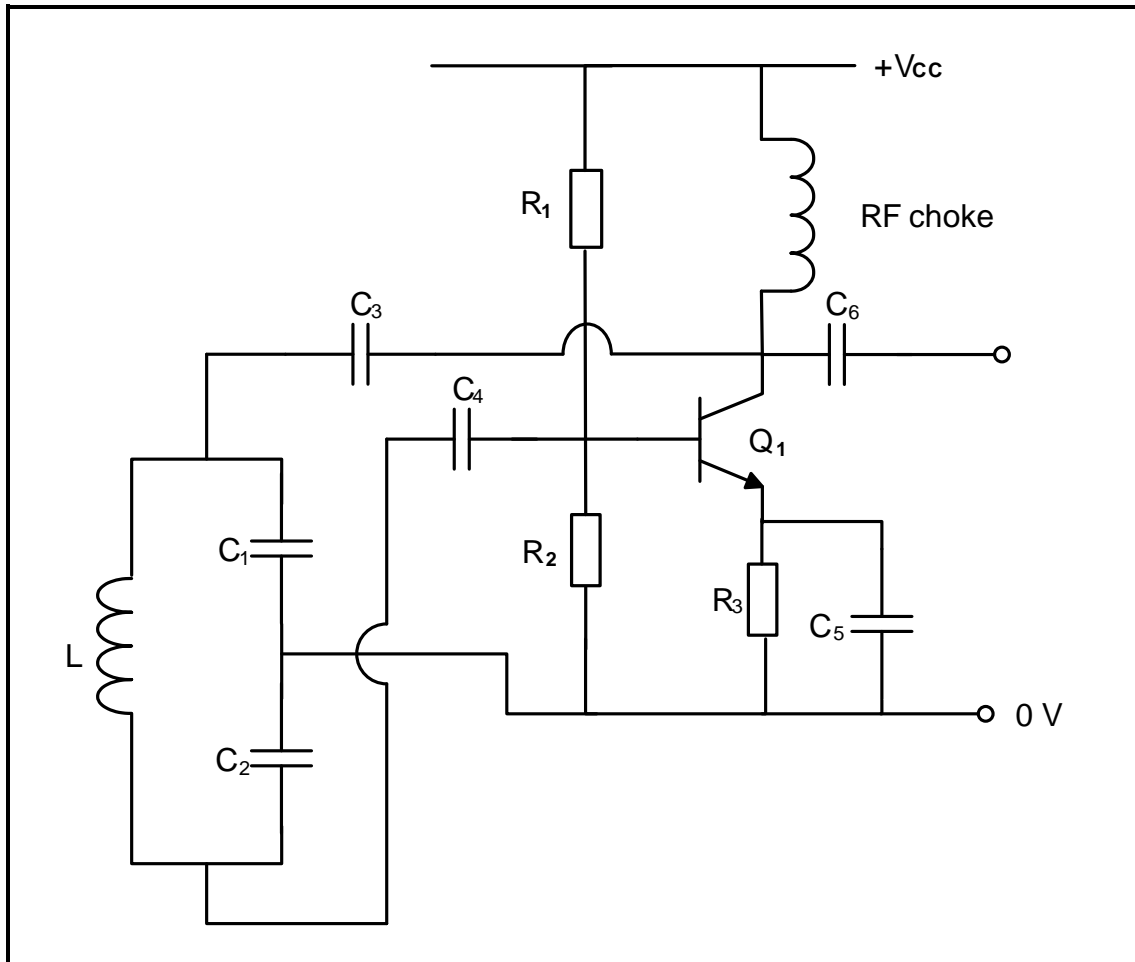

FIGURE 6.9: OSCILLATOR CIRCUIT DIAGRAM

- 6.9.1 Identify the oscillator circuit diagram in FIGURE 6.9. (1)
- 6.9.2 Briefly describe the function of the:
- Amplifier circuit (2)
 - Tank circuit (2)
- 6.9.3 Explain why the feedback network (RF choke and C_3) is regarded as a filter. (2)



- 6.10 Refer to FIGURE 6.10 of an RC-phase shift oscillator and answer the questions that follow.

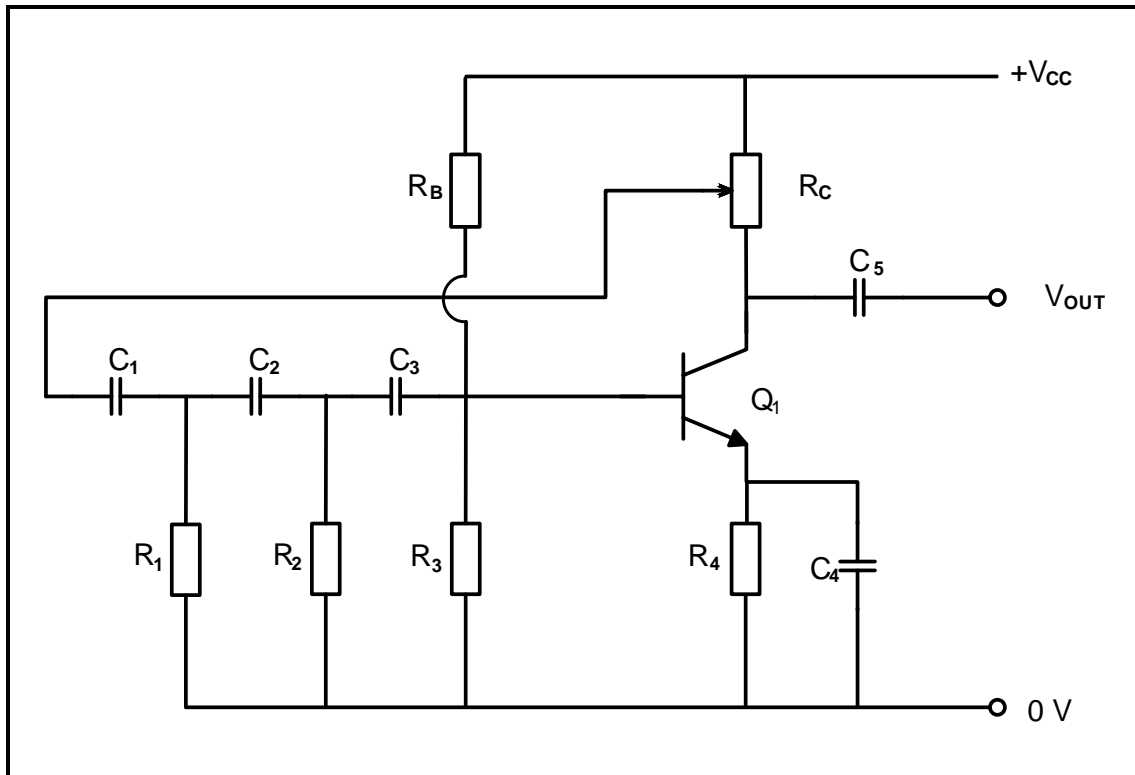

FIGURE 6.10: RC-PHASE SHIFT OSCILLATOR

- 6.10.1 State ONE function of R_3 . (1)
- 6.10.2 Describe how the RC-phase shift oscillator achieves its phase shift of 360° during its operation. (4)
- 6.10.3 Calculate the oscillation frequency of the oscillator circuit if $R_1 = R_2 = R_3 = 10 \text{ k}\Omega$ and $C_1 = C_2 = C_3 = 0,001 \text{ }\mu\text{F}$. (3)

[45]

TOTAL: 200



FORMULA SHEET

RLC CIRCUITS

$$P = V \times I \times \cos \theta$$

$$X_L = 2\pi fL$$

$$X_C = \frac{1}{2\pi fC}$$

$$f_r = \frac{1}{2\pi\sqrt{LC}} \quad \text{OR} \quad f_r = \frac{f_2 + f_1}{2}$$

$$BW = \frac{f_r}{Q} \quad \text{OR} \quad BW = f_2 - f_1$$

SERIES

$$V_R = IR$$

$$V_L = IX_L$$

$$V_C = IX_C$$

$$I_T = \frac{V_T}{Z} \quad \text{OR} \quad I_T = I_R = I_C = I_L$$

$$Z = \sqrt{R^2 + (X_L - X_C)^2}$$

$$V_T = \sqrt{V_R^2 + (V_L - V_C)^2} \quad \text{OR} \quad V_T = IZ$$

$$\cos \theta = \frac{R}{Z} \quad \text{OR} \quad \cos \theta = \frac{V_R}{V_T}$$

$$Q = \frac{X_L}{R} = \frac{X_C}{R} = \frac{V_L}{V_T} = \frac{V_C}{V_T} = \frac{1}{R} \sqrt{\frac{L}{C}}$$

PARALLEL

$$V_T = V_R = V_L = V_C$$

$$I_R = \frac{V_T}{R}$$

$$I_C = \frac{V_T}{X_C}$$

$$I_L = \frac{V_T}{X_L}$$

$$I_T = \sqrt{I_R^2 + (I_L - I_C)^2}$$

$$Z = \frac{V_T}{I_T}$$

$$\cos \theta = \frac{I_R}{I_T}$$

$$Q = \frac{R}{X_L} = \frac{R}{X_C}$$

SEMICONDUCTOR DEVICES

$$\text{Gain } A_V = \frac{V_{OUT}}{V_{IN}} = -\frac{R_F}{R_{IN}} \quad A_V = 1 + \frac{R_F}{R_{IN}}$$

$$V_{OUT} = V_{IN} \times \left(-\frac{R_F}{R_{IN}} \right)$$

$$V_{OUT} = V_{IN} \times \left(1 + \frac{R_F}{R_{IN}} \right)$$

SWITCHING CIRCUITS

$$V_{OUT} = -\left(V_1 \frac{R_F}{R_1} + V_2 \frac{R_F}{R_2} + \dots + V_N \frac{R_F}{R_N} \right)$$

$$\text{Gain } A_V = \frac{V_{OUT}}{V_{IN}} = \frac{V_{OUT}}{(V_1 + V_2 + \dots + V_N)}$$

$$V_{OUT} = -(V_1 + V_2 + \dots + V_N)$$

AMPLIFIERS

$$I_C = \frac{V_C}{R_C} \quad V_{CC} = V_{CE} + I_C R_C$$

$$V_B = V_{BE} + V_{RE}$$

$$A_V = \frac{V_{OUT}}{V_{IN}}$$

$$A_I = \frac{I_{OUT}}{I_{IN}}$$

$$A_P = \frac{P_{OUT}}{P_{IN}} \quad \text{OR} \quad A_P = A_V \times A_I$$

$$\beta_T = \beta_1 \times \beta_2 \quad \text{OR} \quad A_{VT} = A_{V1} \times A_{V2} \times A_{V3} \times \dots \times A_{Vn}$$

$$P_{IN} = I^2 \times Z_{IN} \quad \text{AND} \quad P_{OUT} = I^2 \times Z_{OUT}$$

OSCILLATION FREQUENCY

$$f_o = \frac{1}{2 \times \pi \sqrt{LC}} \quad \text{OR} \quad f_o = \frac{1}{2 \times \pi \sqrt{6RC}}$$

GAIN IN DECIBELS

$$A_I = 20 \log_{10} \frac{I_{OUT}}{I_{IN}}$$

$$A_V = 20 \log_{10} \frac{V_{OUT}}{V_{IN}} \quad \text{OR} \quad A_V = 20 \log_{10} A_{VT}$$

$$A_P = 10 \log_{10} \frac{P_{OUT}}{P_{IN}} \quad \text{OR} \quad A_P = 10 \log_{10} \frac{P_2}{P_1}$$



CENTRE NUMBER:

--	--	--	--	--	--	--	--

EXAMINATION NUMBER:

--	--	--	--	--	--	--	--	--	--	--	--	--	--	--	--

ANSWER SHEET

QUESTION 4: SEMICONDUCTORS

4.2.1
and
4.2.2

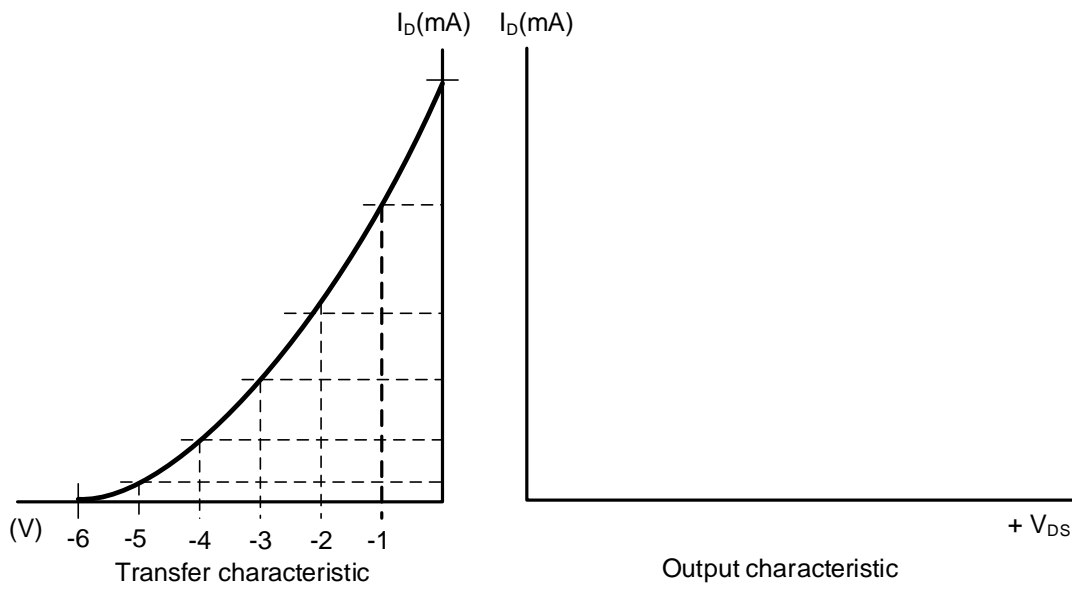

Transfer mark to answer book

MOD

Transfer mark to answer book

MOD

(4.2.1)
FIGURE 4.2

(4.2.2)

(4)

4.3.3

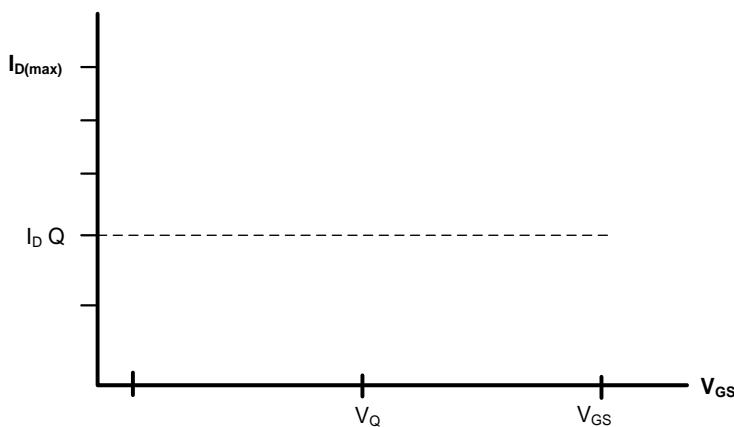

Transfer mark to answer book

MOD

FIGURE 4.3.3

(3)



CENTRE NUMBER:

--	--	--	--	--	--	--	--

EXAMINATION NUMBER:

--	--	--	--	--	--	--	--	--	--	--	--	--	--	--	--	--	--	--	--

ANSWER SHEET

4.7.3

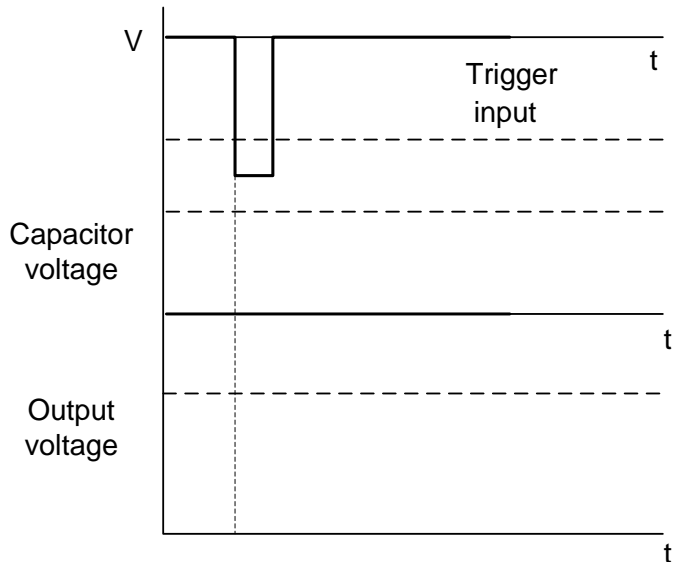

Transfer mark to answer book

--	--

MOD

FIGURE 4.7.3

(4)

QUESTION 5: SWITCHING CIRCUITS

5.3.5

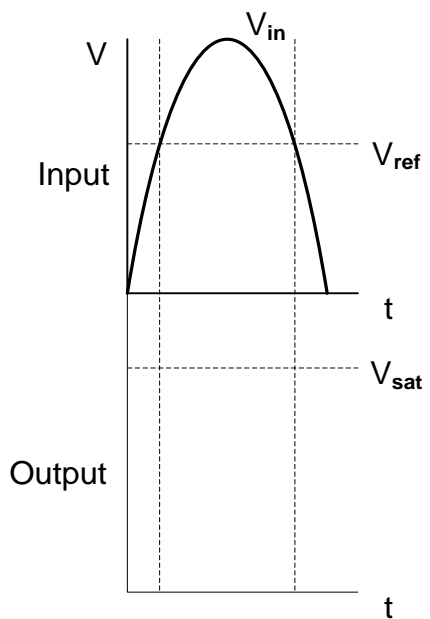

Transfer mark to answer book

--	--

MOD

FIGURE 5.3.5

(3)



CENTRE NUMBER:										
-----------------------	--	--	--	--	--	--	--	--	--	--

EXAMINATION NUMBER:																				
----------------------------	--	--	--	--	--	--	--	--	--	--	--	--	--	--	--	--	--	--	--	--

ANSWER SHEET

5.4.6

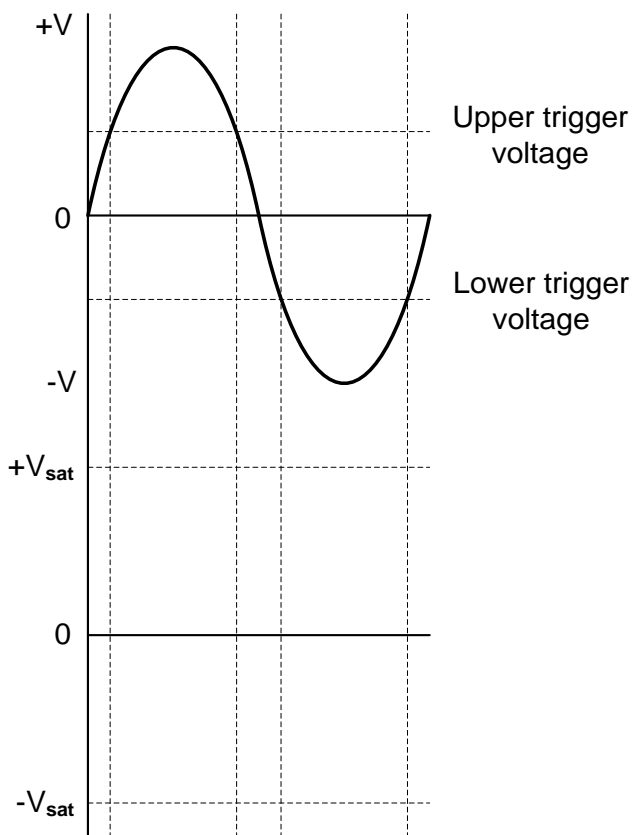

Transfer mark to answer book

--	--

MOD

FIGURE 5.4.6

(4)

5.6.1

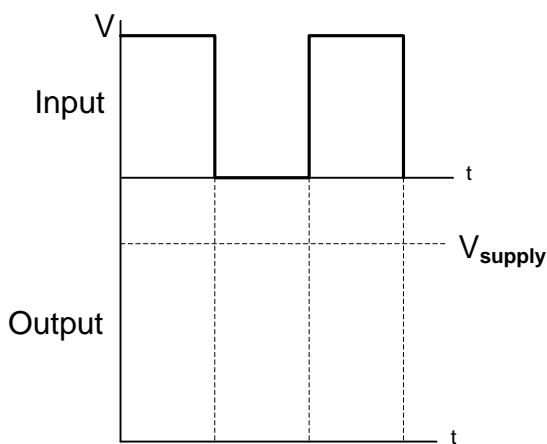

Transfer mark to answer book

--	--

MOD

FIGURE 5.6.1

(3)



CENTRE NUMBER:

--	--	--	--	--	--	--	--

EXAMINATION NUMBER:

--	--	--	--	--	--	--	--	--	--	--	--	--	--	--	--	--	--	--	--

ANSWER SHEET

5.6.2

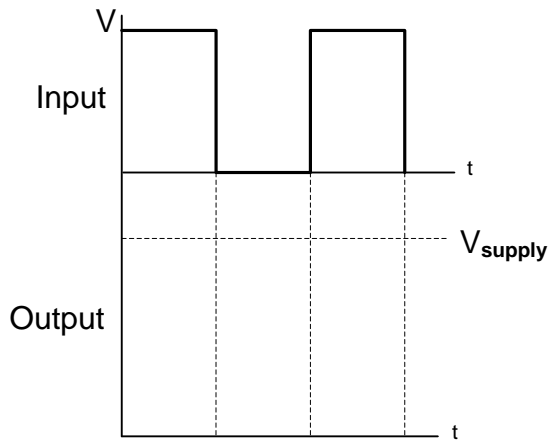

Transfer mark to answer book

--	--

MOD

FIGURE 5.6.2

(3)

QUESTION 6: AMPLIFIERS

6.5.3

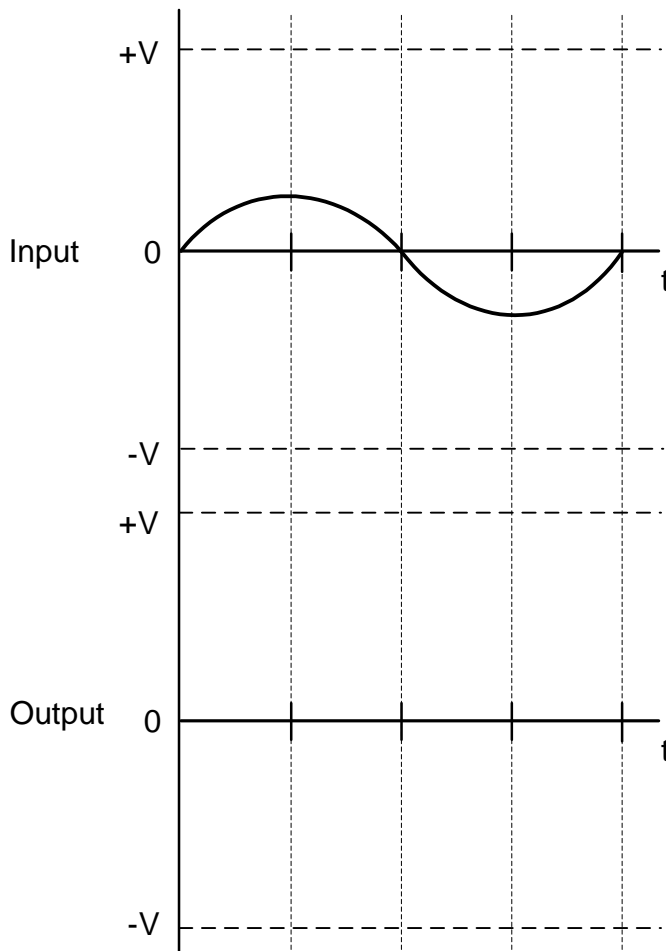

Transfer mark to answer book

--	--

MOD

FIGURE 6.5.3

(3)

